



thermsaver

OIL HEATING SOLUTIONS

CONDENSING & STANDARD EFFICIENCY OIL BOILERS

SEDBUK **BAND A**

up to **97%**

net efficiency

the first name in
oil boilers

OIL BOILERS - FLUES - ACCESSORIES

thermsaver CONDENSING RANGE

condensing kitchen

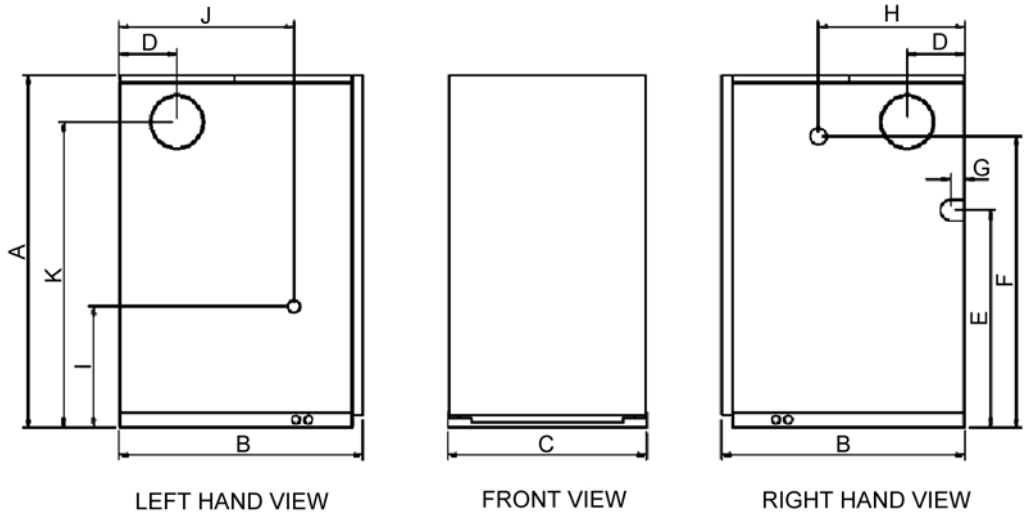

Electrical Supply: 240w-50hz
 Fuel: 28 Second
 Maximum Operating Pressure:
 Draught Limit

General Data
 Oil Supply Connection ¼" BSP
 High Limit Stat: Manual Reset
 3 Bar – 45psi – 28m Static head room 92ft
 Min 12.5 Nm² – 0.05" WG
 Max 33.0 Nm² – 0.12" WG
 Maximum Control Thermostat Setting 85°C

DIMENSION	15/21 KW	21/27 KW	27/38 KW	35/50 KW
A	854	854	854	995
B	589	589	589	657
C	421	481	481	581
D	140	140	140	115
E	496	528	528	628
F	706	706	706	843
G	35	35	35	35
H	355	355	355	370
I	293	293	293	293
J	423	423	423	491
K	741	741	741	889

35/50 Kw addition to range coming shortly

DIMENSIONS ARE IN (mm)

outdoor combi

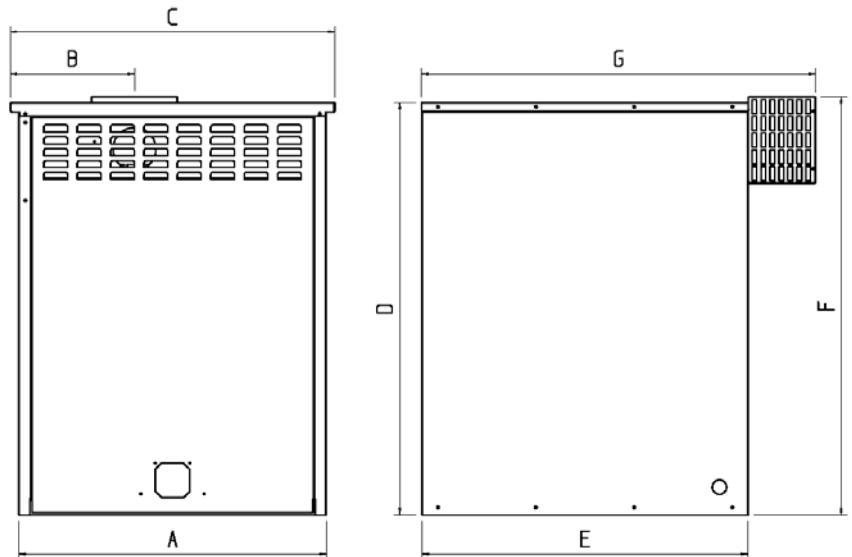

Electrical Supply: 240w-50hz
 Fuel: 28 Second
 Maximum Operating Pressure:
 Draught Limit

General Data
 Oil Supply Connection ¼" BSP
 High Limit Stat: Manual Reset
 3 Bar – 45psi – 28m Static head room 92ft
 Min 12.5 Nm² – 0.05" WG
 Max 33.0 Nm² – 0.12" WG
 Maximum Control Thermostat Setting 85°C

DIMENSION	15/21 KW	21/27 KW	27/38 KW
A	645	645	645
B	260	260	260
C	681	681	681
D	868	868	868
E	684	684	684
F	880	880	880
G	827	827	827

DIMENSIONS ARE IN (mm)



thermsaver CONDENSING RANGE

condensing boilers - how they work

Through a change in legislation, condensing boilers will become more popular. The main principle behind this type of boiler is an increase in efficiency through maintaining the heat for as long as possible within the heat exchanger. This is done with the new, high efficiency condensing heat exchanger which is positioned on top of the boiler shell. In short, maintaining this increases the efficiency with minimum heat being wasted and escaping via the flue.

On standard efficiency boilers, flue gases exit via the flue at a high temperature (200° / 260°C). With a condensing boiler these gases are allowed to pass through a secondary stainless steel heat exchanger, which is positioned on top of the original boiler shell. This secondary exchanger, (like the main exchanger), is filled with water allowing the hot gases more time to transfer to the water and heat the system. One of the by-products of this is the condensate which collects in a specific area of the secondary exchanger and then runs into the condensate trap which is located external to the boiler.

This results in:

- increasing the temperature of the water returning to the main boiler resulting in less energy consumption
- converting some of the gases into this by-product – condensate
- lowering the flue gases to 80°C by efficiently using all the heat to increase the temperature of the water in the system

The thermsaver condensing boiler uses the same boiler design as before with the stainless steel condenser placed on the top of the boiler shell. Benefits include:

- Pre-wired for ease of installation
- Front access for ease of servicing
- Reliable and efficient proven burner
- 5 year guarantee on boiler heat exchanger

thermsaver have the only Boiler House condensing boiler on the market at the moment which should mean value for money for installers who don't need a white cased product for their installation.

The thermsaver condensing boiler boasts a net efficiency of 97% and is included in efficiency Band A products on the SEDBUK list. The lowest rating here is "G" with an efficiency of less than 70% making the thermsaver boiler one of the most efficient on the market.

thermsaver use a unique, multidirectional telescopic flue for ease of siting of the boiler.

boiler house

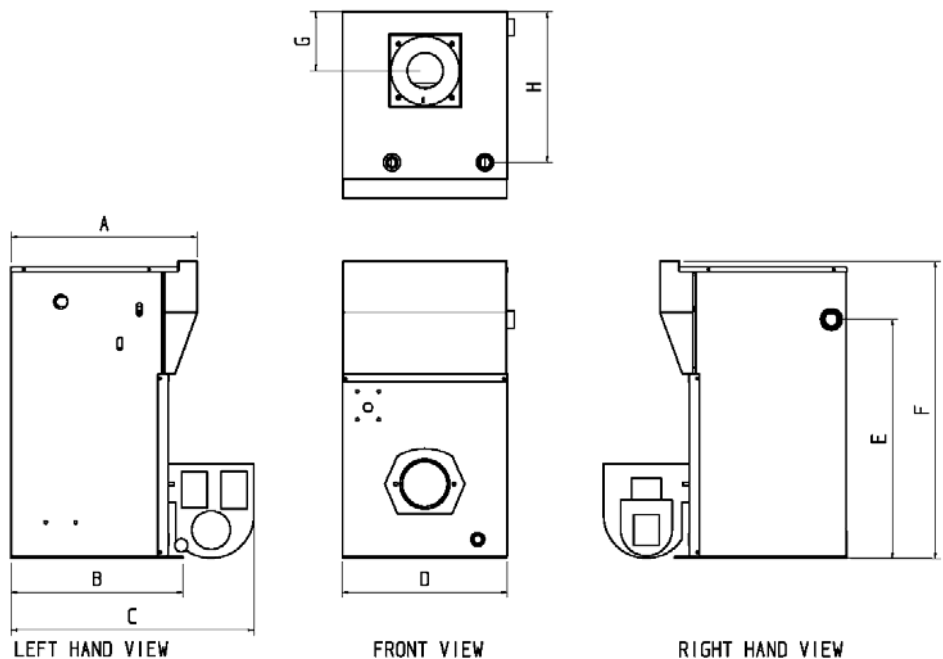

General Data	
Electrical Supply. 240w-50hz	Oil Supply Connection ¼" BSP
Fuel: 28 Second	High Limit Stat: Manual Reset
Maximum Operating Pressure:	3 Bar – 45psi – 28m Static head room 92ft
Draught Limit	Min 12.5 Nm ² – 0.05" WG
	Max 33.0 Nm ² – 0.12" WG
Maximum Control Thermostat Setting	85°C

DIMENSION	15/21 KW	21/27 KW	27/38 KW
A	436	440	440
B	402	402	402
C	568	568	568
D	385	453	453
E	559	527	527
F	694	694	694
G	138	142	142
H	352	357	357



thermsaver CONDENSING RANGE

condensing combi

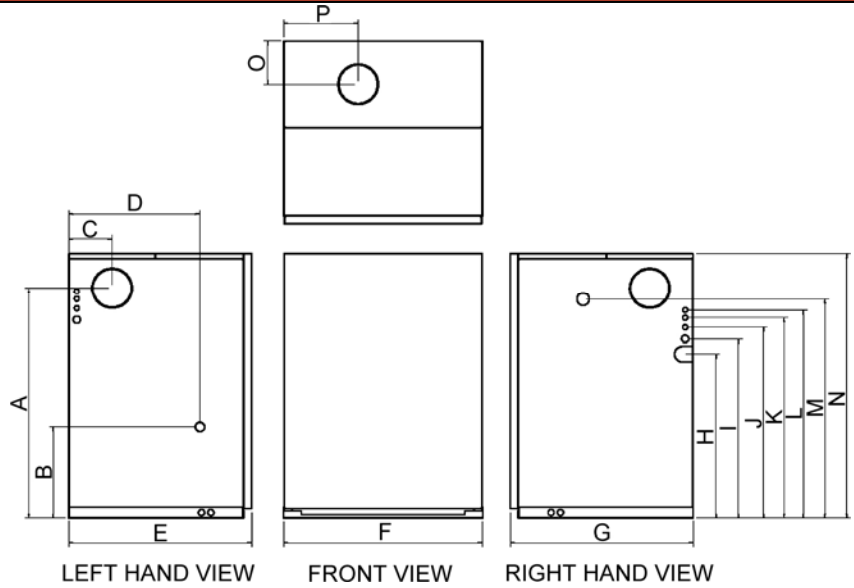

Electrical Supply: 240w-50hz
 Fuel: 28 Second
 Maximum Operating Pressure: 3 Bar – 45psi – 28m Static head room 92ft
 Draught Limit
 Oil Supply Connection ¼" BSP
 High Limit Stat: Manual Reset
 Min 12.5 Nm² – 0.05" WG
 Max 33.0 Nm² – 0.12" WG
 Maximum Control Thermostat Setting 85°C

FITTED WITH A MECHANICAL TIME CLOCK

DIMENSIONS	15/21 KW	21/27 KW	27/38 KW
A	741	741	741
B	293	293	293
C	140	140	140
D	423	423	423
E	589	589	589
F	641	641	641
G	589	589	589
H	528	528	528
I	577	577	577
J	614	614	614
K	645	645	645
L	670	670	670
M	705	705	705
N	854	854	854
O	140	140	140
P	240	240	240

slimline outdoor

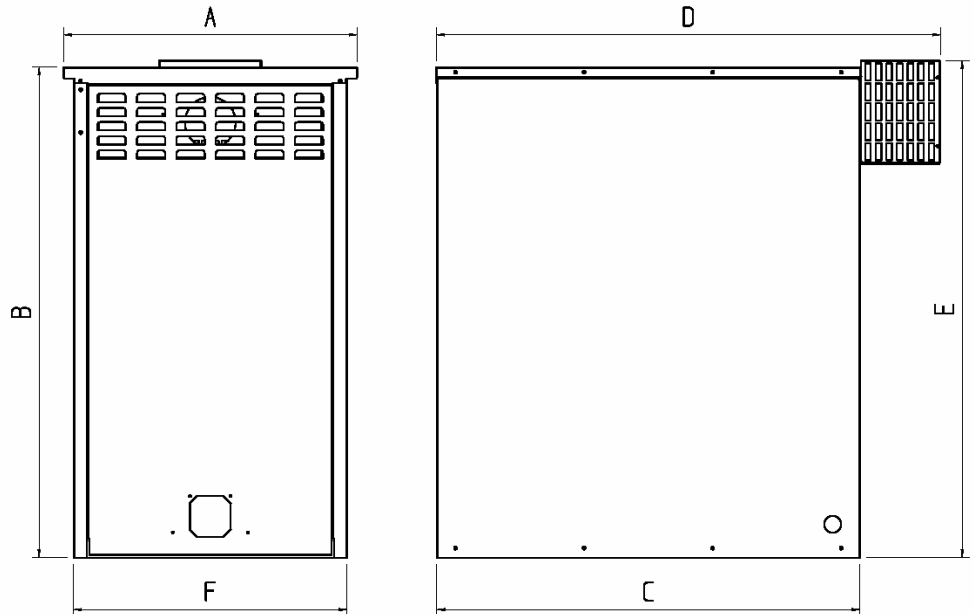

General Data
 Electrical Supply: 240w-50hz
 Fuel: 28 Second
 Maximum Operating Pressure: 3 Bar – 45psi – 28m Static head room 92ft
 Draught Limit
 Oil Supply Connection ¼" BSP
 High Limit Stat: Manual Reset
 Min 12.5 Nm² – 0.05" WG
 Max 33.0 Nm² – 0.12" WG
 Maximum Control Thermostat Setting 85°C

DIMENSIONS	15/21 Kw	21/27 Kw	27/38 Kw
A	521	521	521
B	868	868	868
C	750	750	750
D	894	894	894
E	880	880	880
F	485	485	485

DIMENSIONS ARE IN (mm.)



thermsaver CONDENSING RANGE

thermsaver is the company to rely on with the products you simply fit and forget

thermsaver, established in 1985, supply a complete range of oil boilers and flue accessories designed and manufactured in the UK to ISO and OFTEC standards.

The thermsaver boiler has a **5 year heat exchanger warranty with a 2 year guarantee on the Bentone burner.**

With over 40 years manufacturing experience, reliability and quality are guaranteed.

The entire condensing range is SEDBUK A rated, Part L compliant, Part J in Scotland, and meets all European standards.

Oil boilers have come a long way since the old smelly and noisy appliance located in the cellar. thermsaver boilers operate quietly and efficiently, are factory tested and easy to install.

Whether you are a householder, heating engineer or specifier, we have knowledgeable and friendly staff who are able to answer your sales and technical enquiries for our full range of products.

We are committed to *Best Practice* to ensure correct installation, commissioning and servicing of our appliances.

To enhance our customer support, a full UK service structure is in place.

energy efficiency

Band	SEDBUK range
A	90% and above
B	86% - 90%
C	82% - 86%
D	78% - 82%
E	74% - 78%
F	70% - 74%
G	below 70%

Energy Efficiency Bands - as a simple guide to efficiency, a scheme has been created with SEDBUK efficiency bands assigned to boilers on an "A" to "G" scale. The band is shown in the database and may be used on product literature and labels, though there is no requirement for manufacturers to do so. All thermsaver condensing boilers are SEDBUK Band A up to 94.5%.

multi directional flue systems

To ensure optimum boiler performance and low running noises, thermsaver complement their extensive range of condensing oil boilers with a very simple push fit round flue system.

They are aesthetically pleasing and are also exceptionally easy for the installer. A standard size core drill is all that is needed for installation.

suitable for condensing & standard efficiency boilers

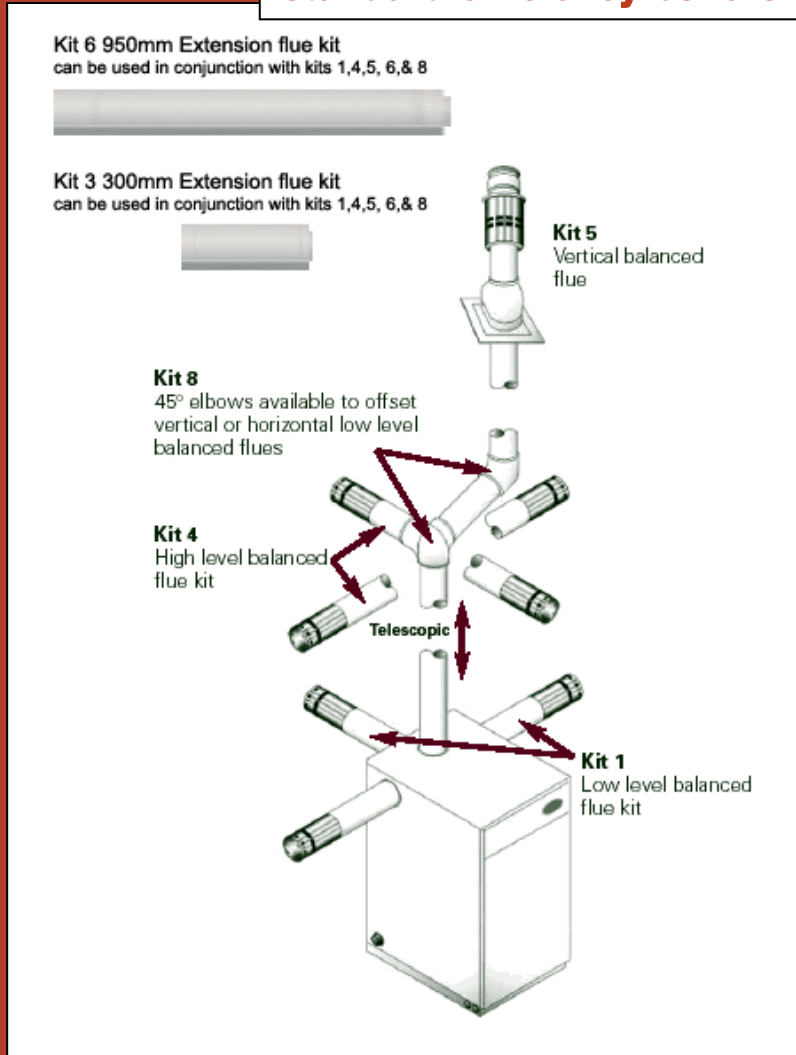

the power to perform

All thermsaver boilers are fitted with the Bentone pressure jet burner, manufactured by the second largest European manufacturer.

The burner has a proven track record of reliability, is easily serviced and ensures a quiet operation of your oil boiler.



The thermsaver oil boiler range is the solution to all domestic heating and hot water applications



thermsaver STANDARD EFFICIENCY RANGE

ALL SEDBUK BAND C



boiler house

DIMENSIONS	50/70 BTU	70/90 BTU	90/120 BTU	115/140 BTU	140/170 BTU	170/220 BTU
Height	717	717	760	860	860	910
Depth	384	384	424	466	466	512
Width	367	367	423	460	460	511

DIMENSIONS ARE IN (mm.)



kitchen deluxe

DIMENSIONS	50/70 BTU	70/90 BTU	90/120 BTU	115/140 BTU	140/170 BTU	170/220 BTU
Height	857	857	896	1025	1025	1075
Depth	590	590	630	671	671	721
Width	420	420	450	490	490	539

DIMENSIONS ARE IN (mm.)



outdoor

	HEIGHT	DEPTH	WIDTH
70/90 BTU Combi	878	630	765
90/115 BTU Combi	916	630	765
70/90 System	878	630	765
50/70 Standard	878	630	765
70/90 Standard	878	630	765
90/115 Standard	878	630	765

DIMENSIONS ARE IN (mm.)

General Data	
Electrical Supply	240w-50hz
Oil Supply Connection	1/4" BSP
Fuel	28 sec or 35 sec
High Limit Stat	Manual Reset
Maximum Control Thermostat Setting	85°C
Maximum Operating Pressure	3 Bar – 45psi



combi/system

	HEIGHT	DEPTH	WIDTH
70/90 BTU Combi	857	590	555
90/115 BTU Combi	950	630	585
50/70 System	857	590	506
70/90 System	857	590	506

DIMENSIONS ARE IN (mm.)

heating controls

these are just some of the heating controls available

ThermSave CELECT DRT2
programmable thermostat



ThermSave CELECT TH-0471
7 day programmer



ThermSave CELECT LCD-RF-3
wireless programmable thermostat



thermsaver

OIL HEATING SOLUTIONS

1 Croftbank Crescent
Uddingston
Glasgow G71 7JD
Tel: 01698 327997
Fax: 01698 327776



thermsaver have a continued research and development programme which occasionally necessitates changes to specifications herein.

Copyright of the contents of this brochure is secured by thermsaver and therefore no part of it may be reproduced without permission.



thermsaver 01698 327997

www.thermsaver.co.uk