

## *Installation, operating and servicing instructions*



**E-Tech 09 - 15**  
**Single phase / Tri phase**

**E-Tech 22 - 28 - 36**  
**Tri phase**



# INDEX

## WARNINGS

Who should read these instructions	3
Symbols	3
Recommendations	3
Applicable standards	3
Importants notes	3
Manual handling instructions	3
Removing the boiler from the packaging	3

## INTRODUCTION

Description of the specifications	4
Lining	4
Heating body	4
Heating elements	4
Equipment	4
Connection	4
Dual stage thermostat	4
Certification	4
Legend	4

## INSTRUCTIONS

User data	6
Setting up	6
Optional internal timeclock	6
Pressure in the heating system	6

## TECHNICAL CHARACTERISTICS

Electrical data of model 09	8
Electrical data of model 15	9
Electrical data of model 22	10
Electrical data of model 28	11
Electrical data of model 36	12

## MOUNTING

Dimensions	13
Wall mounting	13
Installation room	13

## INSTALLATION

Disassembling	14
Heating connection	15
Heating connection + DWL	15
Heating connection + DWL : "Y" plan	16
Heating connection + DWL : "S" plan	16
Electric connection / Models : 09 - 15	17
Electric connection / Models : 22 - 28 - 36	18
Sizing of supply wires	18
Wiring diagrams / Models : 09 - 15 - 22	19
Wiring diagrams / Models : 28 - 36	20
Power wiring / Models : 09 - 15	21
Power wiring / Model : 22	22
Power wiring / Models : 28 - 36	23

## HONEYWELL SUNDIAL WIRING DIAGRAMS

Honeywell Sundial Wiring Centre 'S' Plan	24
Honeywell Sundial Wiring Centre 'Y' Plan	25

## COMMISSIONING AND MAINTENANCE

Commissioning - Water	26
Commissioning - Electrical	26
Starting the boiler	26
Maintenance	26

## REMOVAL THE HEATING ELEMENTS

27

## SPARE PARTS

See at the end of this manual

# WARNINGS

## WHO SHOULD READ THESE INSTRUCTIONS

These instructions should be read by:

- the specifying engineer
- the installer
- the user
- the service engineer

## SYMBOLS



Essential instruction for the correct operation of the installation.



Essential instruction for the safety of persons and the environment.



Danger of electrocution.



Danger of burns

## RECOMMENDATIONS



- These instructions are an integral part of the equipment to which they refer and the user must be provided with a copy.
- The product must be installed and serviced by qualified engineers, in compliance with current standards.
- The manufacturer cannot accept liability for any damage resulting from incorrect installation or from the use of components or fittings not specified by the manufacturer.
- Any failure to follow instructions relating to tests and test procedures may result in personal injury or risks of pollution.
- It is important to switch the boiler off before carrying out any work.
- There are no user parts inside the control panel.

## APPLICABLE STANDARDS



The Boilers have been manufactured to comply with the following standards BS EN60335-2-35: 2002, BS EN55014-1: 2001 and BS EN55014-2:1997.



The installation must be in accordance with the current standards.

## IMPORTANT NOTES

These instructions are an integral part of the equipment to which they relate and must be handed to the user.

The product must be installed and serviced by qualified engineers in accordance with the regulations in force.

The manufacturer declines all liability for any damage caused as a result of incorrect installation or in the event of the use of appliances or accessories that are not specified by the manufacturer.



The manufacturer reserves the right to change the technical characteristics and specification of its products without notice.



The availability of certain versions and their accessories can vary following the market.



Warning : Do not switch ON if there is a possibility that the water in heater is frozen.

## MANUAL HANDLING INSTRUCTIONS



The weight of this boiler is 36Kg, which could present a risk of injury.



Care should be taken when loading and unloading the boiler to and from vehicles.



We recommend that the boiler be handled by two people until it is securely fixed to a wall.



The safest route from the vehicle to the point of installation should be carefully assessed before unloading the boiler.



Mechanical lifting aids should be utilised whenever possible.

## REMOVING THE BOILER FROM THE PACKAGING

- Before lifting the boiler from the packaging, ensure that the installation area is clear and that there are no obstacles making installation difficult or unsafe.
- Lay the boiler on its back (as shown on the box side), open the box and remove the cardboard packaging.
- Remove the polythene cover and the polystyrene corner protection pieces.
- With help from another person, lift the boiler from the packaging holding the lipped front edges of the side panels.
- Do not lift or carry the boiler using the top automatic air vent and bottom pump.

# INTRODUCTION

## DESCRIPTION OF THE SPECIFICATIONS:

This wall hung electric boiler is available in 5 models:

- Models 09 and 15 are supplied with 400 Volt triphase + N, convertible to 230 V single phase.
  - Models 22, 28 and 36 are only supplied with 400 V triphase + N.
- The maximum power can be adjusted for all models by acting on the terminals bridges.



The maximum power can be adjusted for all models by acting on the terminals bridges.

- Model 09: Adjustable power from 4.2 to 8.4 kW
- Model 15: Adjustable power from 7.2 to 14.4 kW
- Model 22: Adjustable power from 14.4 to 21.6 kW
- Model 28: Adjustable power from 21.6 to 28.8 kW
- Model 36: Adjustable power from 30 to 36 kW

## LINING

The boiler is protected by a steel lining that first of all undergoes a degreasing and phosphation process before being lacquered and burnt at 220°C.

## HEATING BODY

The boiler heat exchanger is constructed from mild steel with welded joints. It is hydraulic tested under a pressure of 4.5 bar (maximum working pressure = 3 bar).

## HEATING ELEMENTS

Immersion heaters, constructed from stainless steel Incoloy 800 and mounted in the top of the boiler, provide the power source for the Boiler.

## EQUIPMENT

The boiler is equipped with all the necessary components to allow direct connection to a heating system without the need for a feed and expansion cistern.

These components include; primary 10 litre expansion vessel (suitable for a system water content of up to 160 litres), pressure and temperature gauge, safety valve, circulating pump, low water pressure switch, control and high limit thermostats, on/off and power level switches.

## CONNECTION

The boiler is suitable for connection to most heating and hot water systems, with a maximum working pressure of 3bar and a maximum temperature of 85°C. It can also be used in multiple boiler installations allowing greater outputs to be achieved.

The boiler, and connection glands for both the main power supply and optional external controls are provided, suitable for single or three phase electrical supply depending upon boiler output required.

An internal 3 amp MCB is linked to the incoming electrical supply to provide the internal control circuit, from which optional controls can be connected e.g. internal or external timeclock, room thermostat or Honeywell Sundial controls.

## DUAL STAGE THERMOSTAT

The temperature of the boiler is controlled by a dual stage thermostat which is set by the user to give the desired boiler temperature.

When the boiler has heated up to within 7°C of the set temperature, the thermostat switches off one power stage and therefore reduces the heat input. Thanks to this simple but effective form of modulation, the boiler has longer working cycles and requires less stops and starts, thus resulting in a more even temperature across the boiler. It also means less wear and tear on components and, importantly it uses less power once it has reached working temperature.

## CERTIFICATION

The boilers have been manufactured to comply with the following standards BS EN60335-2-35: 1998, BS EN55014-2:1997 and BS EN50081-1-1: 1992.

## LEGEND

1. Base for relay of DWL priority
2. Control circuit
3. Relay
4. Timer
5. Control terminals
6. Power terminals

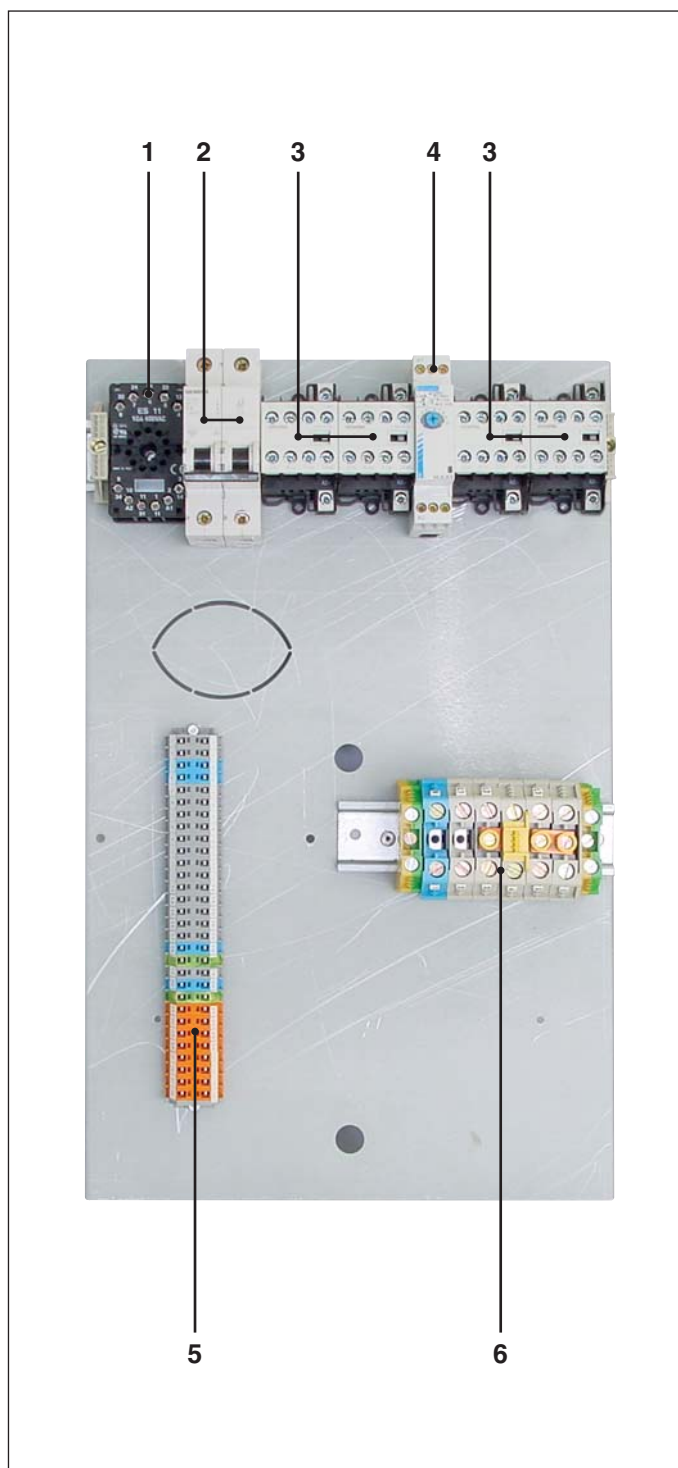

# INTRODUCTION

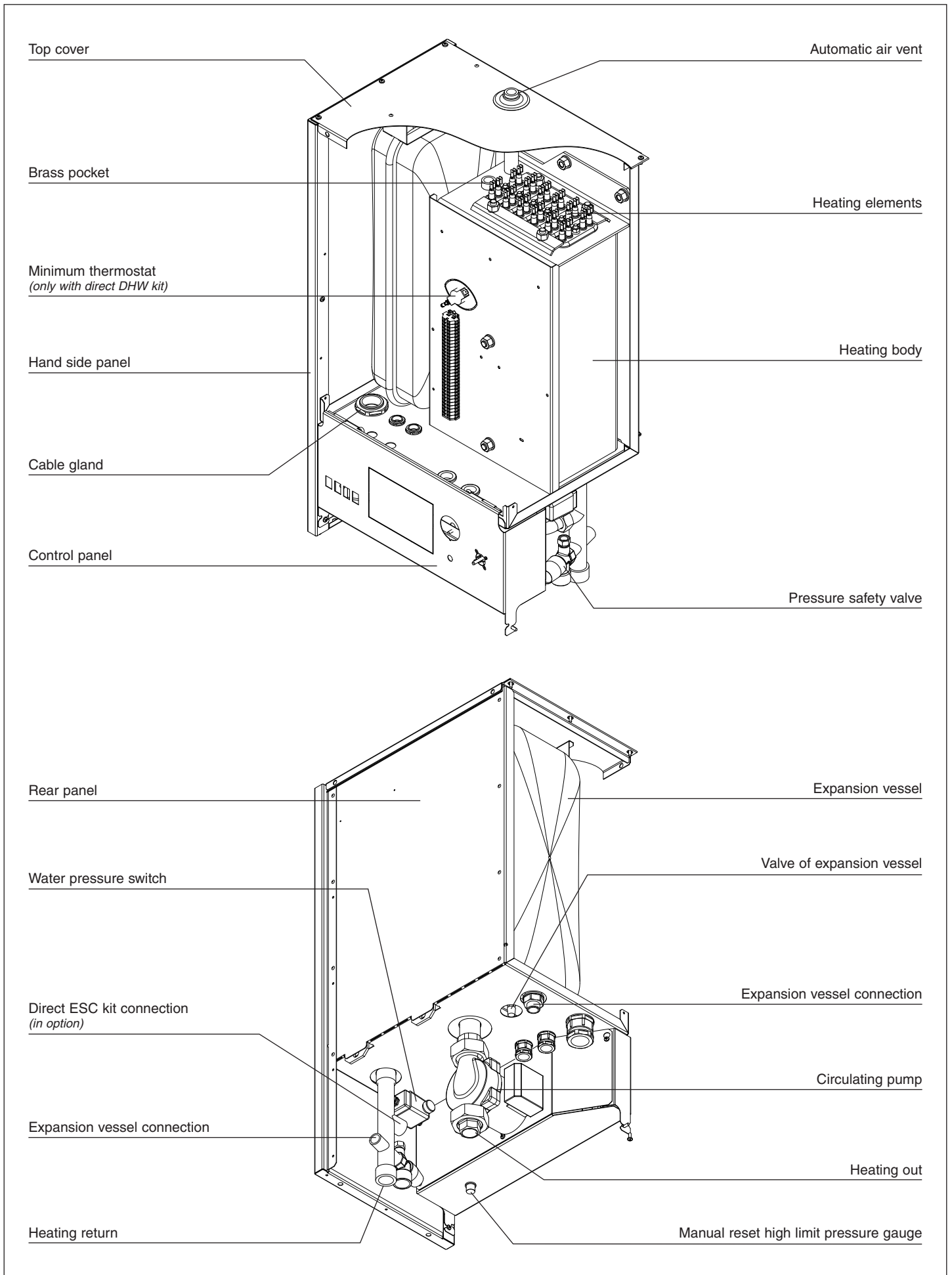

# INSTRUCTIONS

## USER DATA

All user controls are situated on the front panel of the boiler, there are no user controls inside the boiler casing.

The following instructions assume that the boiler has been commissioned, and that the system is filled with water and has been fully vented.

## SETTING UP

- Before switching on any electrical supplies to the boiler ensure that the combined temperature and pressure gauge reads at least 1 bar and the control thermostat is set to the desired temperature.
- If an internal time clock is fitted ensure that this is switched on (see "Optional Internal Time Clock") and if any other auxiliary controls are fitted e.g. programmer, room thermostats, cylinder thermostats etc, consult appropriate manufacturers' instructions to switch these on.
- Switch on any local means of isolation to boiler.
- Switch the boiler on using the ON/OFF switch (the neon light on the switch should now glow).
- Turn on both power level switches - after a short period of time the boiler temperature should start to rise, indicated by the combined temperature and pressure gauge. If the boiler fails to operate, the overheat safety thermostat should be checked. Access to the thermostat reset button is obtained by unscrewing (anti-clockwise) the domed button cover on the front panel (a screwdriver is not required). The reset button can then be seen - press the button, a click should be heard and the button is reset. If no click was heard the device is not at fault and further investigation is required by a suitably qualified engineer.
- The internal clock or external programmer can now be set to allow on/off periods as desired. The ON/OFF switch and 2 power level switches should be left in the ON position during normal use.

 **The power level switches will automatically switch on and off during normal boiler operation, depending on boiler temperature.**

- If the boiler is not in regular daily use during cold periods, it is recommended that it be fitted with a frost sensing thermostat to override the timeclock and prevent the system from freezing.

- As with most boilers and heating appliances the casing and pipework can get hot during normal running so the boiler must not be covered and the surrounding area must be kept clear.

## OPTIONAL INTERNAL TIMECLOCK

- This operates on a 24-hour sequence. Around the outside of the clock there are a number of white tabs - these allow 15 minute switching times. To set a boiler cycle simply push outwards the number of tabs required for your heating period.

Remember : tab OUT = BOILER ON  
tab IN = BOILER OFF

The time of day is marked by an arrow on the inner part of the clock - set the outer time to coincide with this arrow.

On the centre part of the clock there is a switch.

This has three positions :

- Switch down - timeclock off
- Switch middle - timeclock timed (normal position)
- Switch up - timeclock on constant.

## PRESSURE IN THE HEATING SYSTEM

The CH pressure must be a minimum of 1 bar and must be checked by the end user on a regular basis. If the pressure drops under 0.5 bar, the integrated water pressure switch blocks the appliance until the pressure in the system returns to a level above 0.8 bar.

The installer fits the system with a separate fill valve underneath the appliance. Make sure that the appliance is powered off when filling the system. To do this, turn the on/off switch.

For more information, please ask your installer when the system is delivered.

A safety valve is provided underneath the appliance. If the system pressure exceeds 3 bars, this valve opens and drains the water from the system. In this case, please contact your installer.

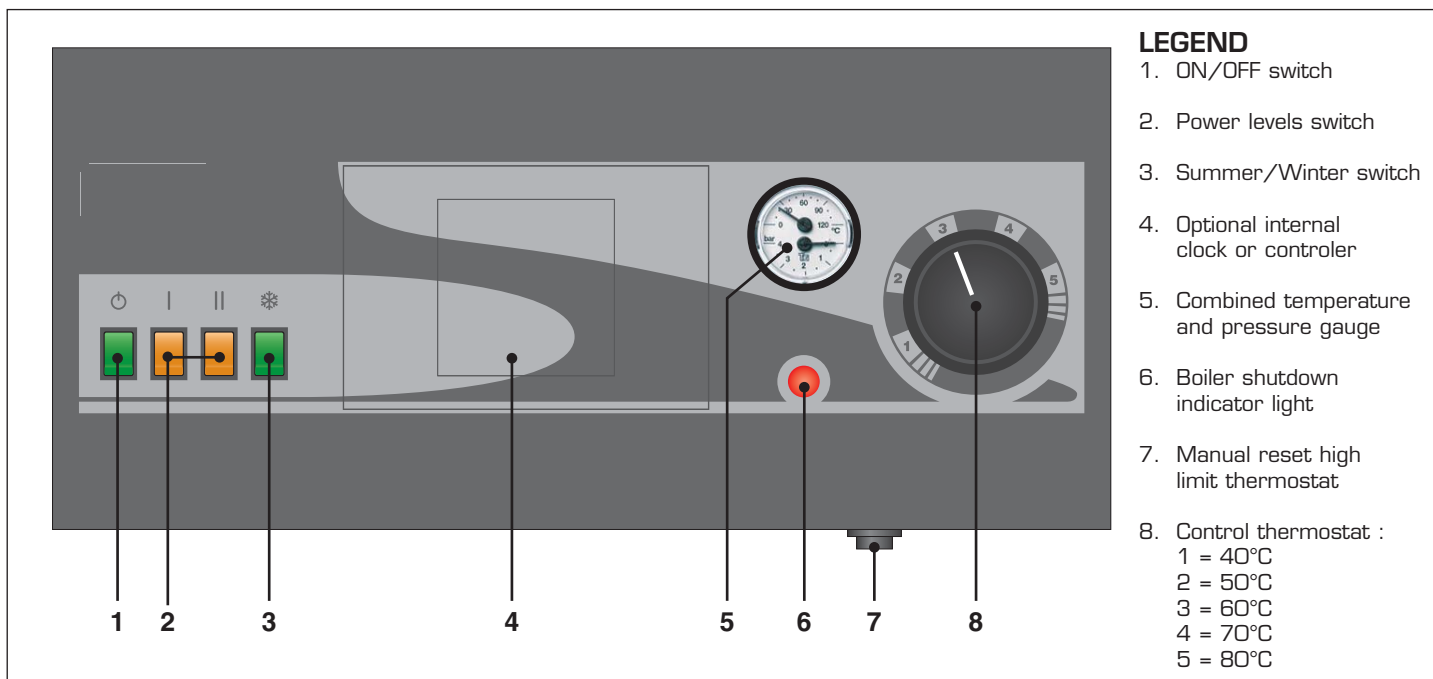

## TECHNICAL CHARACTERISTICS

Model	09	15	22	28	36
<b>Power</b>	4.2 to 8.4 kW	7.2 to 14.4 kW	14.4 to 21.6 kW	21.6 to 28.8 kW	30 to 36 kW
<b>Nominal supply voltage</b>	1 x 230 V or 3 x 400 V + N	1 x 230 V or 3 x 400 V + N	3 x 400 V + N	3 x 400 V + N	3 x 400 V + N
<b>Ohmic resistance of element</b>	37,8 Ohm	22 Ohm	22 Ohm	22 Ohm	17,6 Ohm
<b>Heating element type</b>	2 x 1.4 kW	2 x 2.4 kW	2 x 2.4 kW	2 x 2.4 kW	2 x 3 kW
<b>Number of elements</b>	3	3	5	6	6
<b>Water capacity (Litres)</b>	13	13	13	13	13
<b>Expansion vessel capacity (Litres)</b>	10	10	10	10	10
<b>Max. working pressure (bars)</b>	3	3	3	3	3
<b>Min. working pressure (bars)</b>	0.8	0.8	0.8	0.8	0.8
<b>Max. working temperature (°C)</b>	85	85	85	85	85
<b>Hydraulic pressure drop (mbar)</b>	10	20	45	85	125
<b>Heating connection</b>	3/4"	3/4"	3/4"	3/4"	3/4"
<b>Height (mm)</b>	763	763	763	763	763
<b>Width (mm)</b>	442	442	442	442	442
<b>Depth (mm)</b>	332	332	332	332	332
<b>Weight empty (kg)</b>	45	45	45	45	45

# TECHNICAL CHARACTERISTICS

## Electrical data of model 09

			STAGE 1	STAGE 2	TOTAL	POWER TERMINALS
<b>Tri phase 8.4 kW (*)</b>						
Terminals 1 and 2 shunted	Terminal 3	L1 (A)	6	6	12	
Terminals 5 and 6 shunted	Terminal 4	L2 (A)	12	0	12	
Relay K4 activated	Terminal 5	L3 (A)	6	6	12	
	Terminal 1	N (A)	6	6	0	
	Power	(kW)	5.6	2.8	8.4	
<b>Tri phase 7 kW (***)</b>						
Terminals 1 and 2 shunted	Terminal 3	L1 (A)	6	6	12	
Relay K4 activated	Terminal 4	L2 (A)	12	0	12	
	Terminal 5	L3 (A)	6	0	6	
	Terminal 1	N (A)	6	6	6	
	Power	(kW)	5.6	1.4	7	
<b>Tri phase 5.6 kW (***)</b>						
Terminals 1 and 2 shunted	Terminal 3	L1 (A)	0	6	6	
Terminals 5 and 6 shunted	Terminal 4	L2 (A)	6	0	6	
Relay K4 deactivated (**)	Terminal 5	L3 (A)	6	6	12	
	Terminal 1	N (A)	6	6	6	
	Power	(kW)	2.8	2.8	5.6	
<b>Tri phase 4.2 kW</b>						
Terminals 1 and 2 shunted	Terminal 3	L1 (A)	0	6	6	
Relay K4 deactivated (**)	Terminal 4	L2 (A)	6	0	6	
	Terminal 5	L3 (A)	6	0	6	
	Terminal 1	N (A)	6	6	0	
	Power	(kW)	2.8	1.4	4.2	
<b>Single phase 8.4 kW</b>						
Terminals 1 and 2 shunted	Terminal 3	L1 (A)	24	12	36	
Terminals 3, 4, 5 and 6 shunted	Terminal 1	N (A)	24	12	36	
Relay K4 activated	Power	(kW)	5.6	2.8	8.4	
<b>Single phase 7 kW</b>						
Terminals 1 and 2 shunted	Terminal 3	L1 (A)	24	6	30	
Terminals 3, 4 and 5 shunted	Terminal 1	N (A)	24	6	30	
Relay K4 activated	Power	(kW)	5.6	1.4	7	
<b>Single phase 5.6 kW</b>						
Terminals 1 and 2 shunted	Terminal 3	L1 (A)	12	12	24	
Terminals 3, 4 and 5 shunted	Terminal 1	N (A)	12	12	24	
Relay K4 deactivated (**)	Power	(kW)	2.8	2.8	5.6	
<b>Single phase 4.2 kW</b>						
Terminals 1 and 2 shunted	Terminal 3	L1 (A)	12	6	31.2	
Terminals 3, 4 and 5 shunted	Terminal 1	N (A)	12	6	31.2	
Relay K4 deactivated (**)	Power	(kW)	2.8	1.4	4.2	

This values are based on standard supply voltage in Europe, that is 1 x 230V for single phase and 3 x 400V + N for tri phase.

(\*) Factory configuration / (\*\*) Remove the shunt 21 and 22 in order to deactivate the relay / (\*\*\*) Current not balanced.

# TECHNICAL CHARACTERISTICS

## Electrical data of model 15

			STAGE 1	STAGE 2	TOTAL	POWER TERMINALS
<b>Tri phase 14.4 kW (*)</b>						
Terminals 1 and 2 shunted	Terminal 3	L1 (A)	10.4	10.4	20.8	
Terminals 5 and 6 shunted	Terminal 4	L2 (A)	20.8	0	20.8	
Relay K4 activated	Terminal 5	L3 (A)	10.4	10.4	20.8	
	Terminal 1	N (A)	10.4	10.4	0	
	Power	(kW)	9.6	4.8	14.4	
<b>Tri phase 12 kW (***)</b>						
Terminals 1 and 2 shunted	Terminal 3	L1 (A)	10.4	10.4	20.8	
Relay K4 activated	Terminal 4	L2 (A)	20.8	0	20.8	
	Terminal 5	L3 (A)	10.4	0	10.4	
	Terminal 1	N (A)	10.4	10.4	10.4	
	Power	(kW)	9.6	2.4	12	
<b>Tri phase 9.6 kW (***)</b>						
Terminals 1 and 2 shunted	Terminal 3	L1 (A)	0	10.4	10.4	
Terminals 5 and 6 shunted	Terminal 4	L2 (A)	10.4	0	10.4	
Relay K4 deactivated (**)	Terminal 5	L3 (A)	10.4	10.4	20.8	
	Terminal 1	N (A)	10.4	10.4	10.4	
	Power	(kW)	4.8	4.8	9.6	
<b>Tri phase 7.2 kW</b>						
Terminals 1 and 2 shunted	Terminal 3	L1 (A)	0	10.4	10.4	
Relay K4 deactivated (**)	Terminal 4	L2 (A)	10.4	0	10.4	
	Terminal 5	L3 (A)	10.4	0	10.4	
	Terminal 1	N (A)	10.4	10.4	0	
	Power	(kW)	4.8	2.4	7.2	
<b>Single phase 14.4 kW</b>						
Terminals 1 and 2 shunted	Terminal 3	L1 (A)	41.6	20.8	62.4	
Terminals 3, 4, 5 and 6 shunted	Terminal 1	N (A)	41.6	20.8	62.4	
Relay K4 activated	Power	(kW)	9.6	4.8	14.4	
<b>Single phase 12 kW</b>						
Terminals 1 and 2 shunted	Terminal 3	L1 (A)	41.6	10.4	52	
Terminals 3, 4 and 5 shunted	Terminal 1	N (A)	41.6	10.4	52	
Relay K4 activated	Power	(kW)	9.6	2.4	12	
<b>Single phase 9.6 kW</b>						
Terminals 1 and 2 shunted	Terminal 3	L1 (A)	20.8	20.8	41.6	
Terminals 3, 4 and 5 shunted	Terminal 1	N (A)	20.8	20.8	41.6	
Relay K4 deactivated (**)	Power	(kW)	4.8	4.8	9.6	
<b>Single phase 7.2 kW</b>						
Terminals 1 and 2 shunted	Terminal 3	L1 (A)	20.8	10.4	31.2	
Terminals 3, 4 and 5 shunted	Terminal 1	N (A)	20.8	10.4	31.2	
Relay K4 deactivated (**)	Power	(kW)	4.8	2.4	7.2	

This values are based on standard supply voltage in Europe, that is 1 x 230V for single phase and 3 x 400V + N for tri phase.

(\*) Factory configuration / (\*\*) Remove the shunt 21 and 22 in order to deactivate the relay / (\*\*\*) Current not balanced.

# TECHNICAL CHARACTERISTICS

## Electrical data of model 22

			STAGE 1	STAGE 2	TOTAL	POWER TERMINALS
<b>Tri phase 21.6 kW (*)</b>						
Terminals 3 and 4 shunted	Terminal 2	L1 (A)	20.8	10.4	31.2	<p>1 2 3 4 5 6 N L1 L2 L3</p>
Terminals 5 and 6 shunted	Terminal 3	L2 (A)	20.8	10.4	31.2	
Relay K4 activated	Terminal 5	L3 (A)	20.8	10.4	31.2	
	Terminal 1	N (A)	0	0	0	
	Power	(kW)	14.4	7.2	21.6	
<b>Tri phase 19.2 kW (***)</b>						
Terminals 3 and 4 shunted	Terminal 2	L1 (A)	20.8	10.4	31.2	<p>1 2 3 4 5 6 N L1 L2 L3</p>
Relay K4 activated	Terminal 3	L2 (A)	20.8	10.4	31.2	
	Terminal 5	L3 (A)	10.4	10.4	20.8	
	Terminal 1	N (A)	10.4	0	10.4	
	Power	(kW)	12	7.2	19.2	
<b>Tri phase 16.8 kW (***)</b>						
Relay K4 activated	Terminal 2	L1 (A)	20.8	10.4	31.2	<p>1 2 3 4 5 6 N L1 L2 L3</p>
	Terminal 3	L2 (A)	10.4	10.4	20.8	
	Terminal 5	L3 (A)	10.4	10.4	20.8	
	Terminal 1	N (A)	10.4	0	10.4	
	Power	(kW)	9.6	7.2	16.8	
<b>Tri phase 14.4 kW</b>						
Terminals 3 and 4 shunted	Terminal 2	L1 (A)	10.4	10.4	20.8	<p>1 2 3 4 5 6 N L1 L2 L3</p>
Terminals 5 and 6 shunted	Terminal 3	L2 (A)	10.4	10.4	20.8	
Relay K4 deactivated (**)	Terminal 5	L3 (A)	10.4	10.4	20.8	
	Terminal 1	N (A)	0	0	0	
	Power	(kW)	7.2	7.2	14.4	

*This values are based on standard supply voltage in Europe, that is 1 x 230V for single phase and 3 x 400V + N for tri phase.*

*(\*) Factory configuration / (\*\*) Remove the shunt 21 and 22 in order to deactivate the relay / (\*\*\*) Current not balanced.*

# TECHNICAL CHARACTERISTICS

## Electrical data of model 28

			STAGE 1	STAGE 2	TOTAL	POWER TERMINALS
<b>Tri phase 28.8 kW (*)</b>						
Terminals 3 and 4 shunted	Terminal 2	L1 (A)	20.8	20.8	41.6	<p>1 2 3 4 5 6 N L1 L2 L3</p>
Terminals 5 and 6 shunted	Terminal 3	L2 (A)	20.8	20.8	41.6	
Relay K5 activated	Terminal 5	L3 (A)	20.8	20.8	41.6	
	Terminal 1	N (A)	0	0	0	
	Power	(kW)	14.4	14.4	28.8	
<b>Tri phase 26.4 kW (***)</b>						
Terminals 3 and 4 shunted	Terminal 2	L1 (A)	20.8	20.8	41.6	<p>1 2 3 4 5 6 N L1 L2 L3</p>
Relay K5 activated	Terminal 3	L2 (A)	20.8	20.8	41.6	
	Terminal 5	L3 (A)	20.8	10.4	31.2	
	Terminal 1	N (A)	0	10.4	10.4	
	Power	(kW)	14.4	12	26.4	
<b>Tri phase 24 kW (***)</b>						
Relay K5 activated	Terminal 2	L1 (A)	20.8	20.8	41.6	<p>1 2 3 4 5 6 N L1 L2 L3</p>
	Terminal 3	L2 (A)	20.8	10.4	31.2	
	Terminal 5	L3 (A)	20.8	10.4	31.2	
	Terminal 1	N (A)	0	10.4	10.4	
	Power	(kW)	14.4	9.6	24	
<b>Tri phase 21.6 kW</b>						
Terminals 3 and 4 shunted	Terminal 2	L1 (A)	20.8	10.4	31.2	<p>1 2 3 4 5 6 N L1 L2 L3</p>
Terminals 5 and 6 shunted	Terminal 3	L2 (A)	20.8	10.4	31.2	
Relay K5 deactivated (**)	Terminal 5	L3 (A)	20.8	10.4	31.2	
	Terminal 1	N (A)	0	0	0	
	Power	(kW)	14.4	7.2	21.6	

*This values are based on standard supply voltage in Europe, that is 1 x 230V for single phase and 3 x 400V + N for tri phase.*

*(\*) Factory configuration / (\*\*) Remove the shunt 23 and 24 in order to deactivate the relay / (\*\*\*) Current not balanced.*

# TECHNICAL CHARACTERISTICS

## Electrical data of model 36

			STAGE 1	STAGE 2	TOTAL	POWER TERMINALS
<b>Tri phase 36 kW (*)</b>						
Terminals 3 and 4 shunted	Terminal 2	L1 (A)	26	26	52	
Terminals 5 and 6 shunted	Terminal 3	L2 (A)	26	26	52	
Relay K5 activated	Terminal 5	L3 (A)	26	26	52	
	Terminal 1	N (A)	0	0	0	
	Power	(kW)	18	18	36	
<b>Tri phase 34 kW (***)</b>						
Terminals 3 and 4 shunted	Terminal 2	L1 (A)	26	26	52	
Relay K5 activated	Terminal 3	L2 (A)	26	26	52	
	Terminal 5	L3 (A)	26	13	39	
	Terminal 1	N (A)	0	13	13	
	Power	(kW)	18	15	33	
<b>Tri phase 32 kW (***)</b>						
Relay K5 activated	Terminal 2	L1 (A)	26	26	52	
	Terminal 3	L2 (A)	26	13	43	
	Terminal 5	L3 (A)	26	13	43	
	Terminal 1	N (A)	0	13	13	
	Power	(kW)	18	14	30	
<b>Tri phase 30 kW</b>						
Terminals 3 and 4 shunted	Terminal 2	L1 (A)	26	13	43	
Terminals 5 and 6 shunted	Terminal 3	L2 (A)	26	13	43	
Relay K5 deactivated (**)	Terminal 5	L3 (A)	26	13	43	
	Terminal 1	N (A)	0	0	0	
	Power	(kW)	18	9	27	

*This values are based on standard supply voltage in Europe, that is 1 x 230V for single phase and 3 x 400V + N for tri phase.  
 (\*) Factory configuration / (\*\*) Remove the shunt 23 and 24 in order to deactivate the relay / (\*\*\*) Current not balanced.*

# MOUNTING

## DIMENSIONS

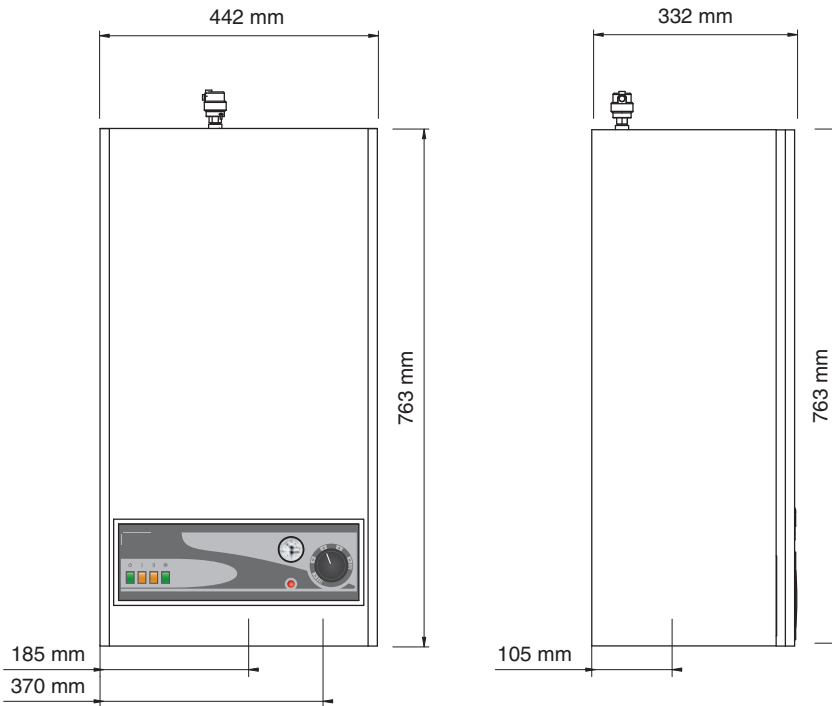

## WALL MOUNTING

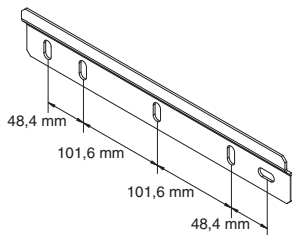

- The boiler must be fixed to a non flammable wall.
- Observing the clearances shown below, drill 2 off 14mm x 100mm holes.
- Fit the 2 bolts supplied and hang the wall bracket.
- Fit washers and nuts
- Hang the boiler

## FROST PROTECTION

The boiler is **NOT** fitted with frost protection. If the boiler is being installed in a position where freezing could take place, then a suitable external frost thermostat should be fitted.

## CONNECTING TO THE SYSTEM

The boiler is designed to operate on a sealed system (ie. no open vent or feed and expansion cistern) Hot water expansion within the system is taken up by the internal 10 litre expansion vessel. This is suitable for systems up to 160 litres capacity. If the system capacity is more than this then an additional expansion vessel may be required. This can be fitted external to the boiler at a convenient place on the pipework.

Please note that the circulation pump is fitted to the flow connection.

## INSTALLATION ROOM

The appliance must be positioned in such a way as to be easily accessible at all times. In addition, the following minimum distances around the appliance must be complied with.

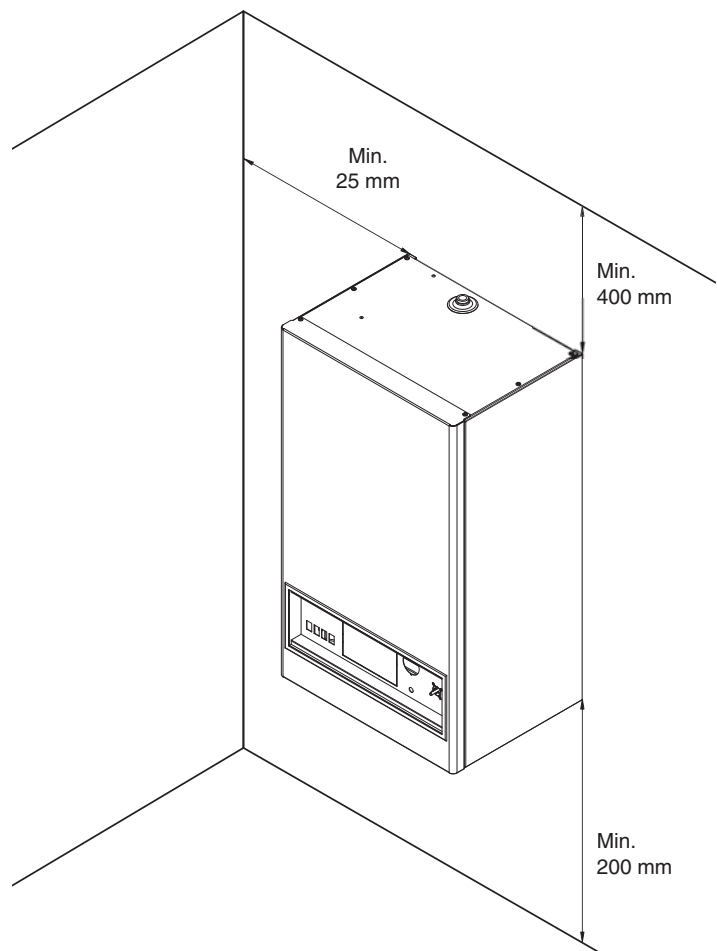

# INSTALLATION

## DISASSEMBLING

### Panel removal and access to hydraulic connections

1. Undo screws.
2. Tilt panel towards you and lift clear remove the top cover.
3. Loosen screws of the control panel.
4. Turn up the control panel.
5. Block the control panel with the screw.

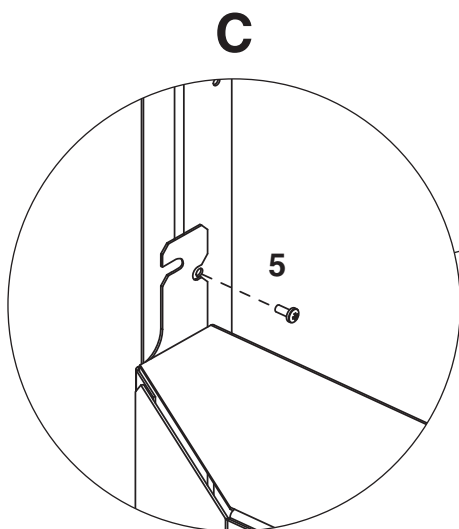
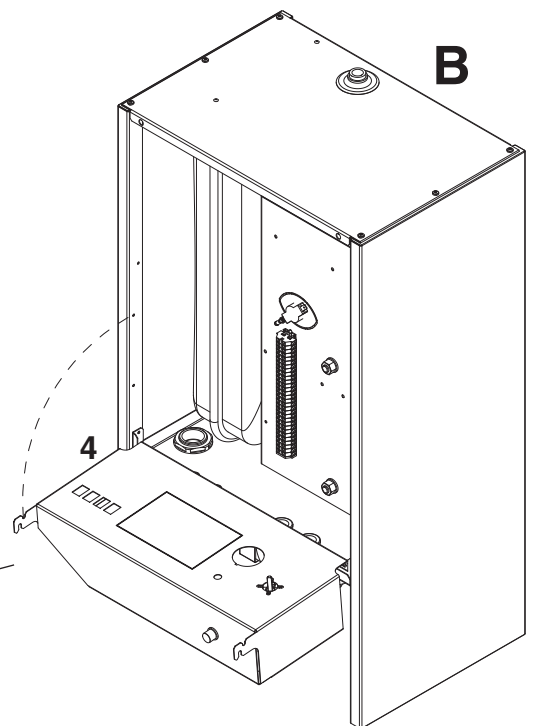
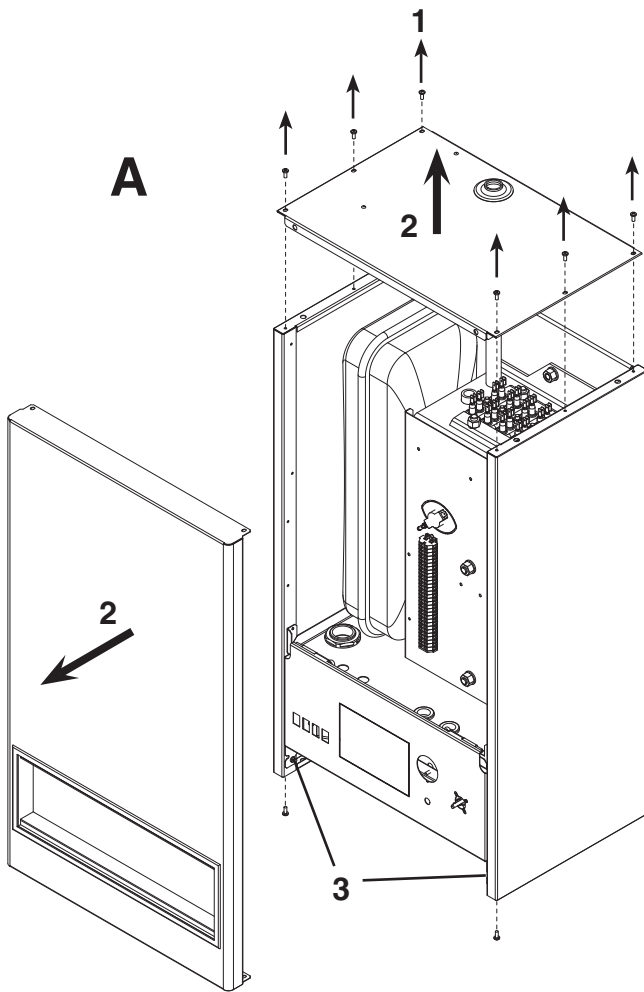

# INSTALLATION

## HEATING CONNECTION

Limiting the maximum adjustable temperature

Factory setting  
30 - 85°C

Floor heating  
30 - 50°C

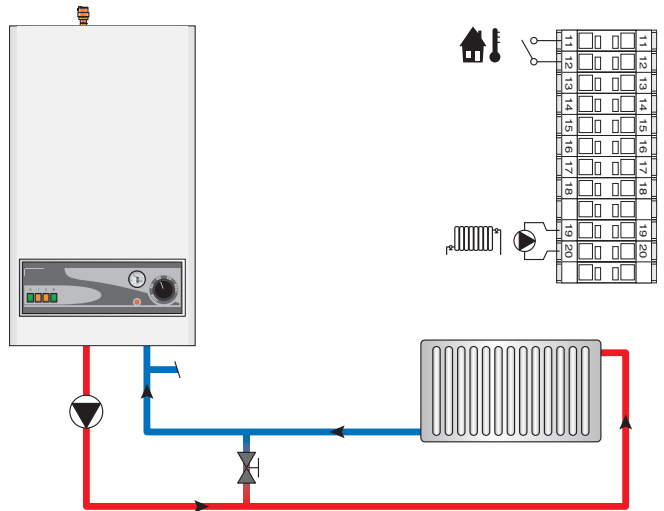
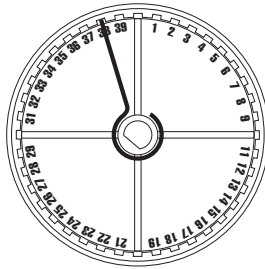

## HEATING CONNECTION + DHW (Circulating pump + 3-way valve)

Limiting the maximum adjustable temperature

With DHW kit  
60 - 85°C

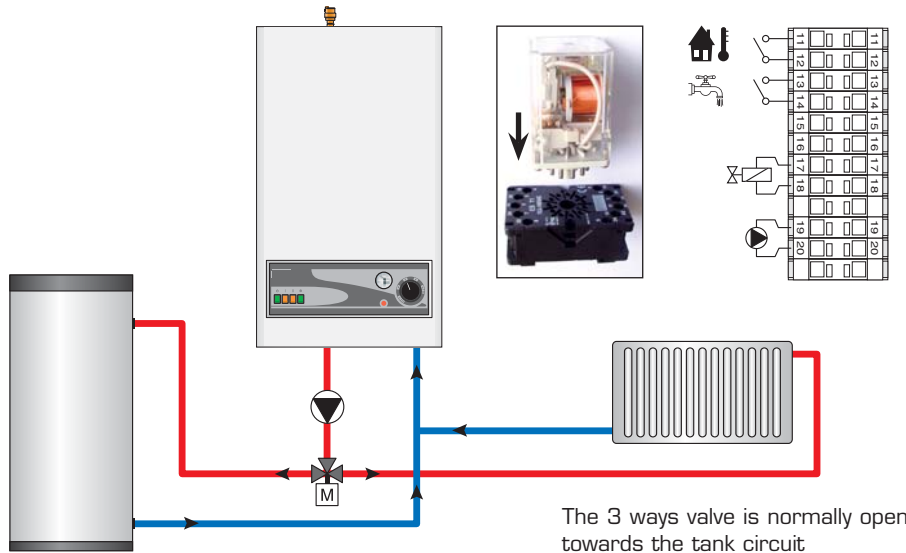
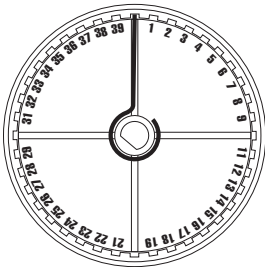

## HEATING CONNECTION + DHW (2 Circulating pumps)

Limiting the maximum adjustable temperature

With DHW kit  
60 - 85°C

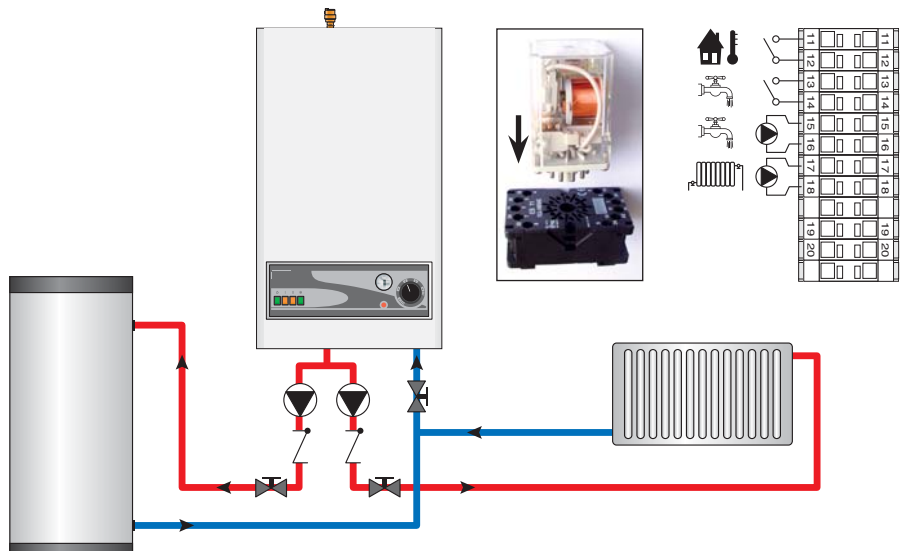
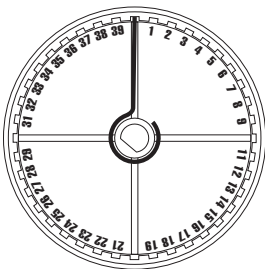

# INSTALLATION

## HEATING CONNECTION + DHW : "Y" PLAN

Limiting the maximum adjustable temperature

60 - 85°C

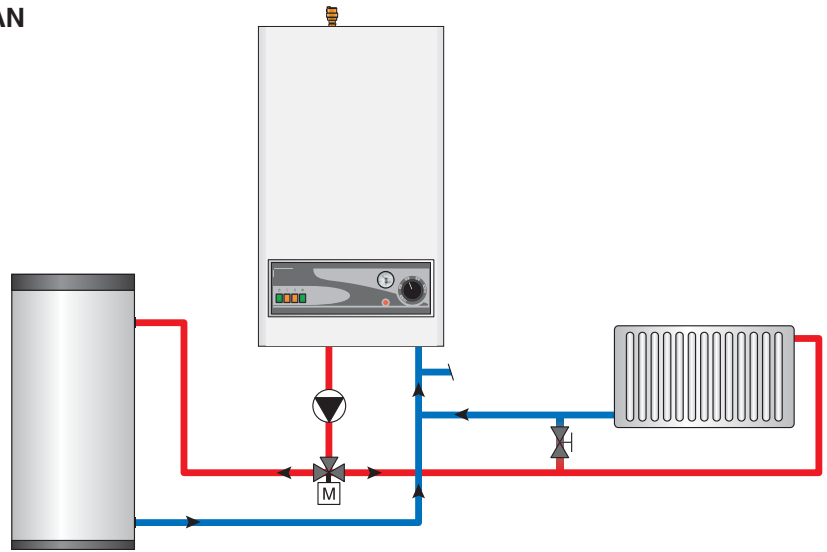
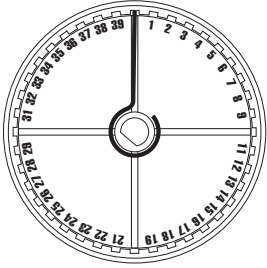

## HEATING CONNECTION + DHW : "S" PLAN

Limiting the maximum adjustable temperature

60 - 85°C

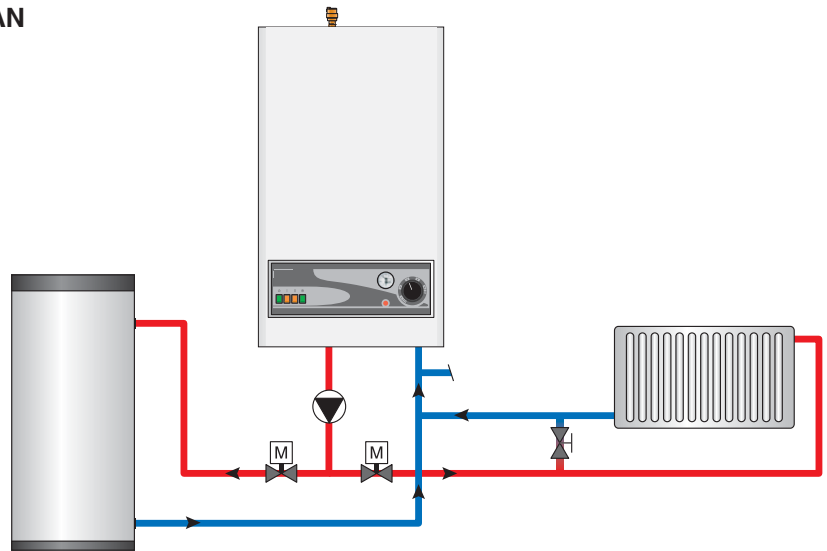
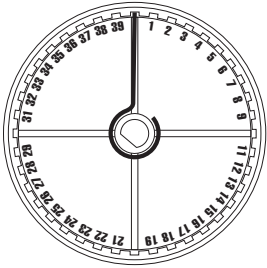

# INSTALLATION

## ELECTRIC CONNECTION / MODELS : 09 - 15



- This appliance must be permanently connected to fixed wiring and must be earthed.
- The wiring must be carried out by a competent person and in accordance with the current IEE Wiring Regulations.
- Isolation device must be provided with a minimum contact clearance of 3 mm.
- The MCB must be readily accessible and adjacent to the appliance.

**Power supply  
230 V mono**

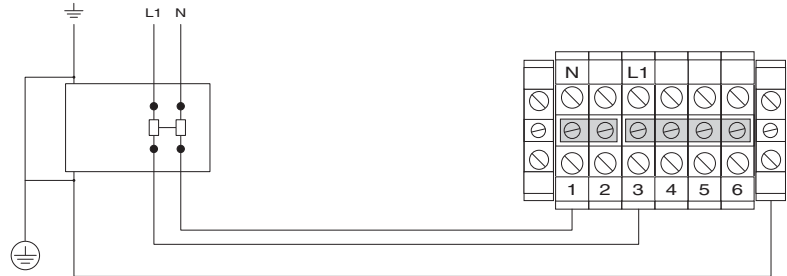

**Power supply  
230 V mono + Safety contactor**



The safety contactor is not supplied by ACV

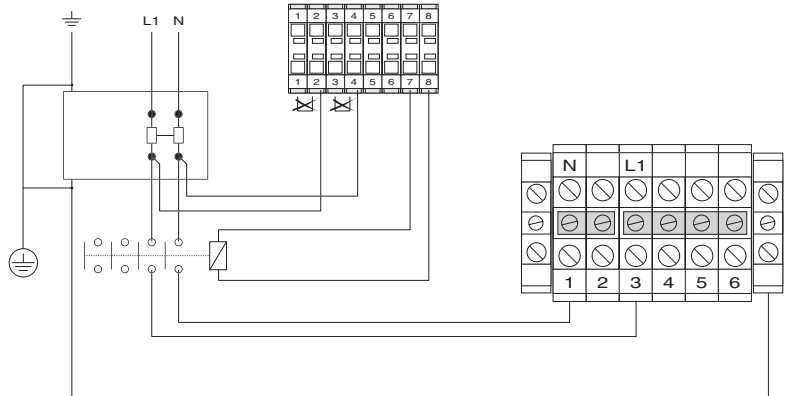

**Power supply  
3 x 400 V + Neutral**

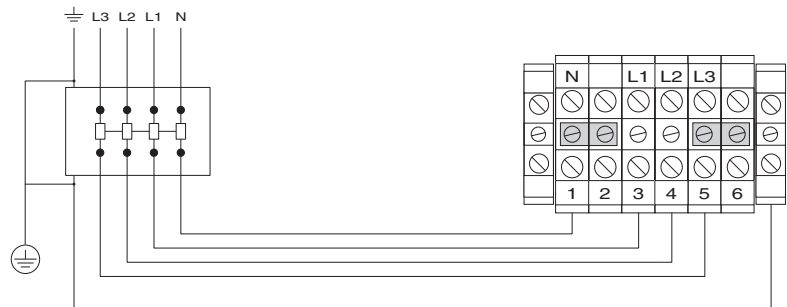

**Power supply  
3 x 400 V + Neutral + Safety contactor**



The safety contactor is not supplied by ACV

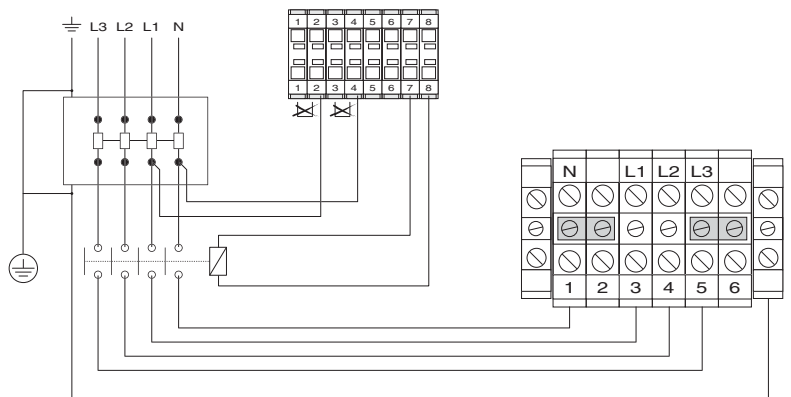

# INSTALLATION

## ELECTRIC CONNECTION / MODELS : 22 - 28 - 36



- This appliance must be permanently connected to fixed wiring and must be earthed.
- The wiring must be carried out by a competent person and in accordance with the current IEE Wiring Regulations.
- Isolation device must be provided with a minimum contact clearance of 3 mm.
- The MCB must be readily accessible and adjacent to the appliance.

Power supply  
3 x 400 V + Neutral

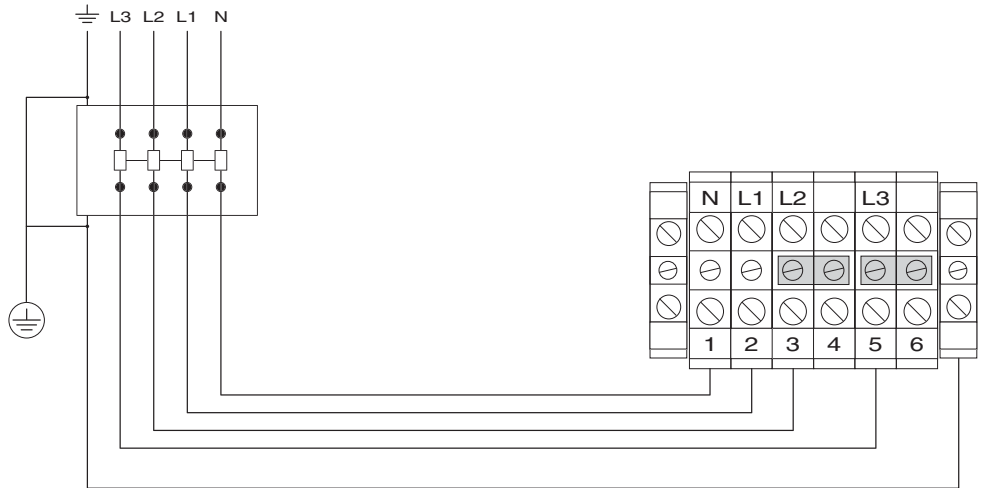

Power supply  
3 x 400 V + Neutral +  
Safety contactor



The safety contactor is  
not supplied by ACV

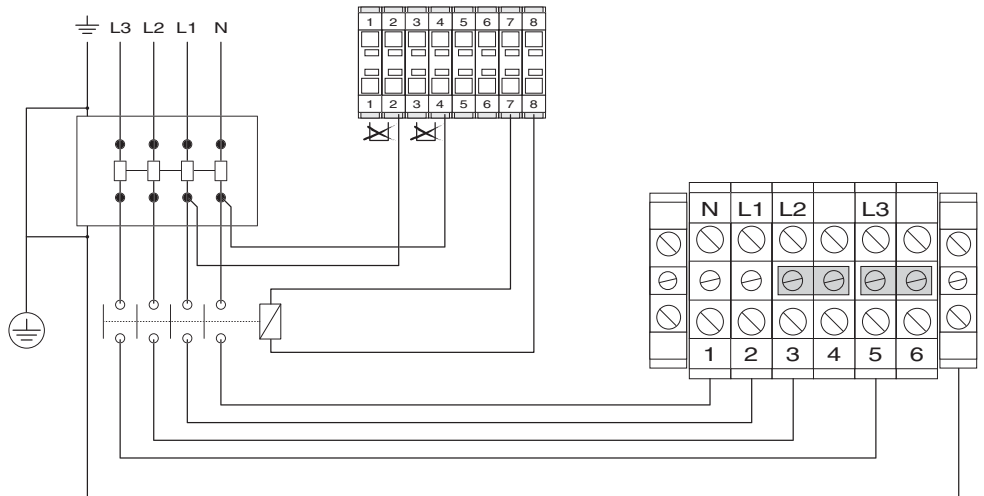

### SIZING OF SUPPLY WIRES

The supply wires are sized depending of the type and current of the MCB. This last firstly sized depending of the nominal current of the boiler. The admissible current of the supply wires depends of the ambient temperature, the section and length of the wires, the wires insulation, the wires canalisation, the mounting and the environment.

The following values are given for information for an ambient temperature of 30°C and a maximal length of 5 meters. In all the cases, the installation must be in accordance with the current IEE Wiring Regulations.

Nominal section (mm)	Nominal current of the MCB (A)
1.5	16
2.5	25
4	32
6	40
10	63
16	80

# WIRING DIAGRAMS / MODELS : 09 - 15 - 22

## INSTALLATION

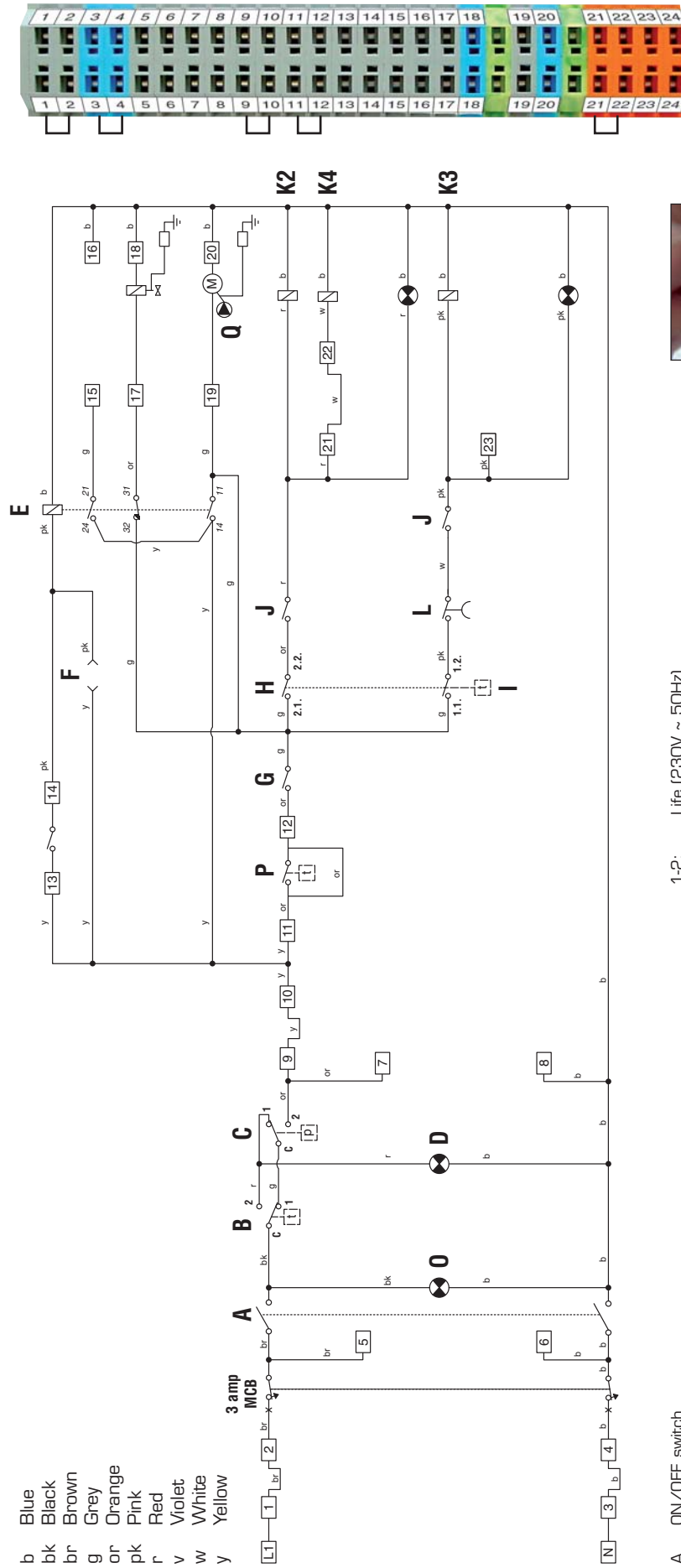

- b Blue
- bk Black
- br Brown
- g Grey
- or Orange
- pk Pink
- r Red
- v Violet
- w White
- y Yellow

- A ON/OFF switch
- B Manual reset high limit thermostat
- C Water pressure switch
- D Alarm indicator
- E DHW priority relay (optional)
- F Minimum thermostat (with direct DHW kit)
- G Summer / Winter switch
- H Boiler thermostat 60 - 85°C
- I Boiler thermostat 78 - 53°C
- J Power level switch
- K2 Power relay 1 - level 1
- K3 Power relay 1 - level 2
- K4 Power relay 2 - level 1
- L Timer
- O Switch indicator
- P Room thermostat (optional)
- Q Boiler pump

- 1-2: Life (230V ~ 50Hz)
- 3-4: Neutral
- 5-6: Time clock (optional)
- 7-8: Master Relay (optional)
- 9-10: Stop Bridge
- 11-12: Room thermostat (optional)
- 13-14: Domestic hot water thermostat (optional)
- 15-16: Domestic hot water pump
- 17-18: 3 ways valve (optional)
- 19-20: Boiler pump
- 21-22: Relay K4 deactivated



# WIRING DIAGRAMS / MODELS : 28 - 36

## INSTALLATION

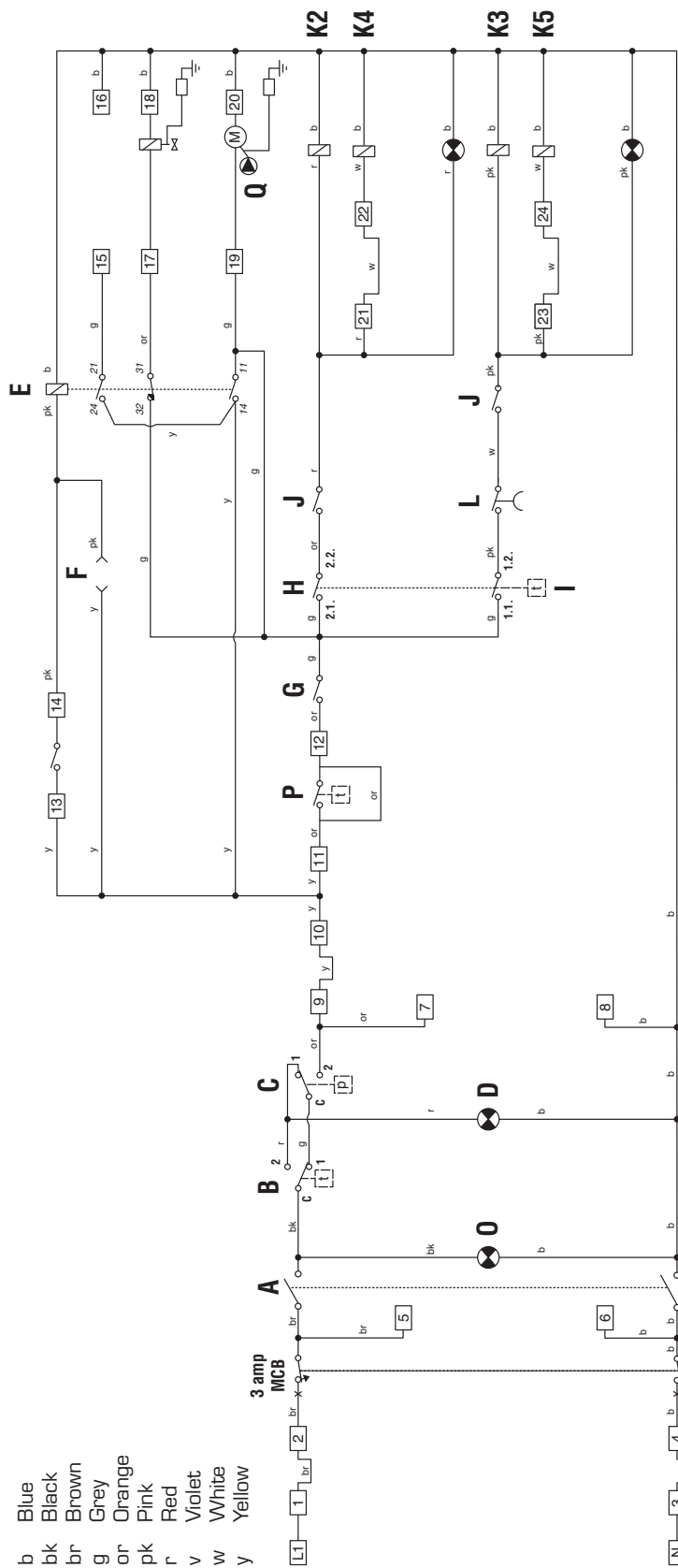
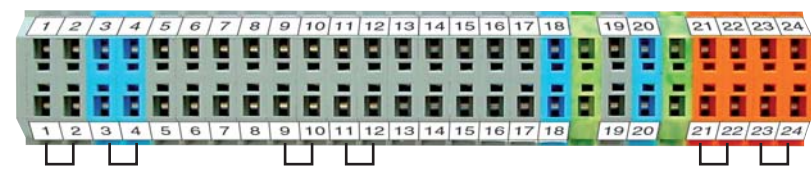

- b Blue
- bk Black
- br Brown
- g Grey
- or Orange
- pk Pink
- r Red
- v Violet
- w White
- y Yellow

- A ON/OFF switch
- B Manual reset high limit thermostat
- C Water pressure switch
- D Alarm indicator
- E DHW priority relay (optional)
- F Minimum thermostat (with direct DHW kit)
- G Summer / Winter switch
- H Boiler thermostat 60 - 85°C
- I Boiler thermostat 78 - 53°C
- J Power level switch
- K2 Power relay 1 - level 1
- K3 Power relay 1 - level 2
- K4 Power relay 2 - level 1
- K5 Power relay 2 - level 2
- L Timer
- O Switch indicator
- P Room thermostat (optional)
- Q Boiler pump

- 1-2: Life (230V ~ 50Hz)
- 3-4: Neutral
- 5-6: Time clock (optional)
- 7-8: Master Relay (optional)
- 9-10: Stop Bridge
- 11-12: Room thermostat (optional)
- 13-14: Domestic hot water thermostat (optional)
- 15-16: Domestic hot water pump
- 17-18: 3 ways valve (optional)
- 19-20: Boiler pump
- 21-22: Relay K4 deactivated
- 23-24: Relay K5 deactivated

# POWER WIRING / MODELS : 09 - 15

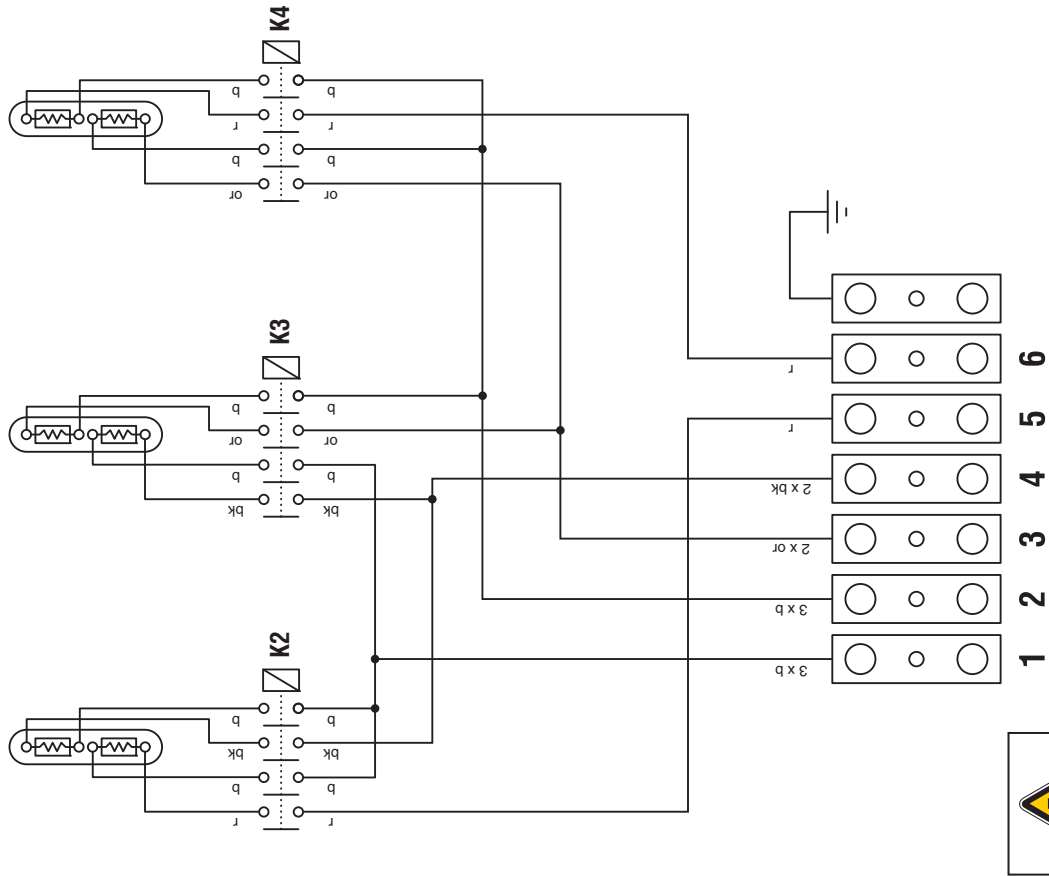

Type 9	8,4 kW	7 kW	5,6 kW	4,2 kW
Type 15	14,4 kW	12 kW	9,6 kW	7,2 kW
<b>TRI PHASE</b>	 1 2 3 4 5 6 N L1 L2 L3	 1 2 3 4 5 6 N L1 L2 L3 Current not balanced	 1 2 3 4 5 6 N L1 L2 L3 Current not balanced	 1 2 3 4 5 6 N L1 L2 L3 Current not balanced
<b>SINGLE PHASE</b>	 1 2 3 4 5 6 N L	 1 2 3 4 5 6 N L	 1 2 3 4 5 6 N L	 1 2 3 4 5 6 N L
	 21 22	 21 22	 21 22	 21 22

# INSTALLATION

## POWER WIRING / MODEL : 22

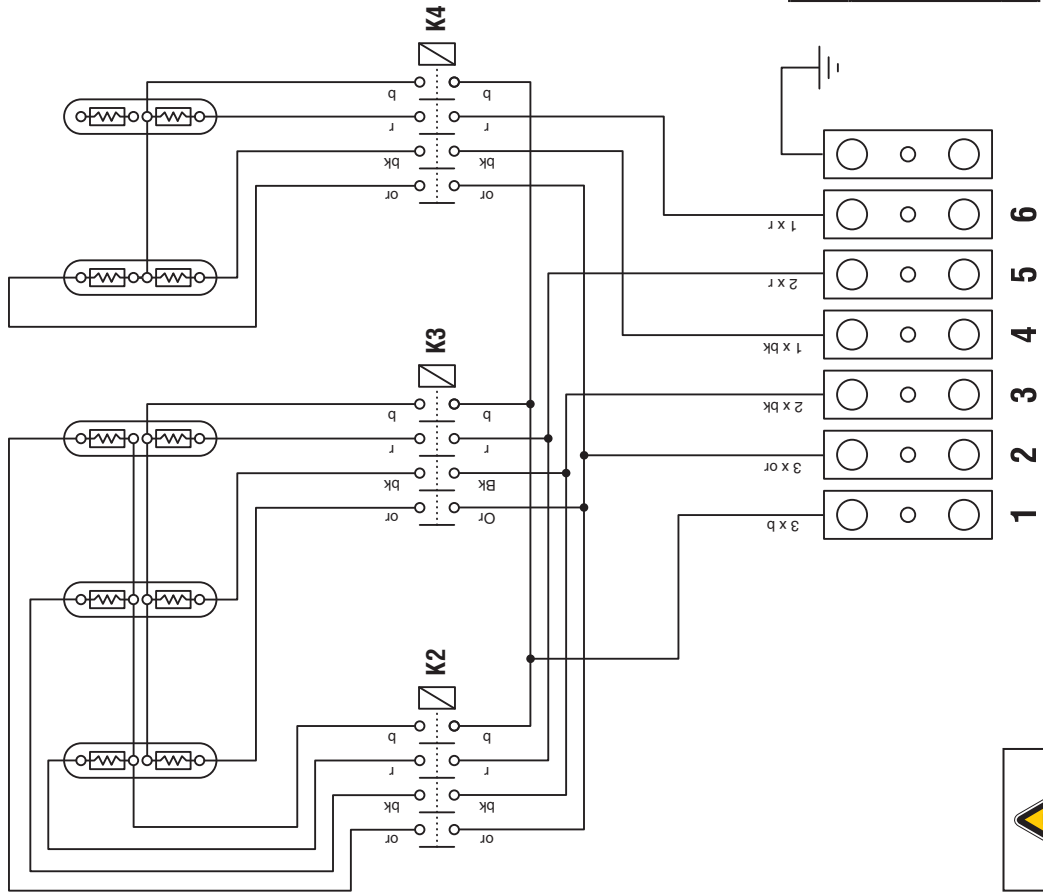

Type 22	21,6 kW	19,2 kW	16,8 kW	14,4 kW
<b>TRI PHASE</b>				
	1 N L1 L2 L3	1 N L1 L2 L3	1 N L1 L2 L3	1 N L1 L2 L3
	Current not balanced	Current not balanced	Current not balanced	

# POWER WIRING / MODELS : 28 - 36

## INSTALLATION

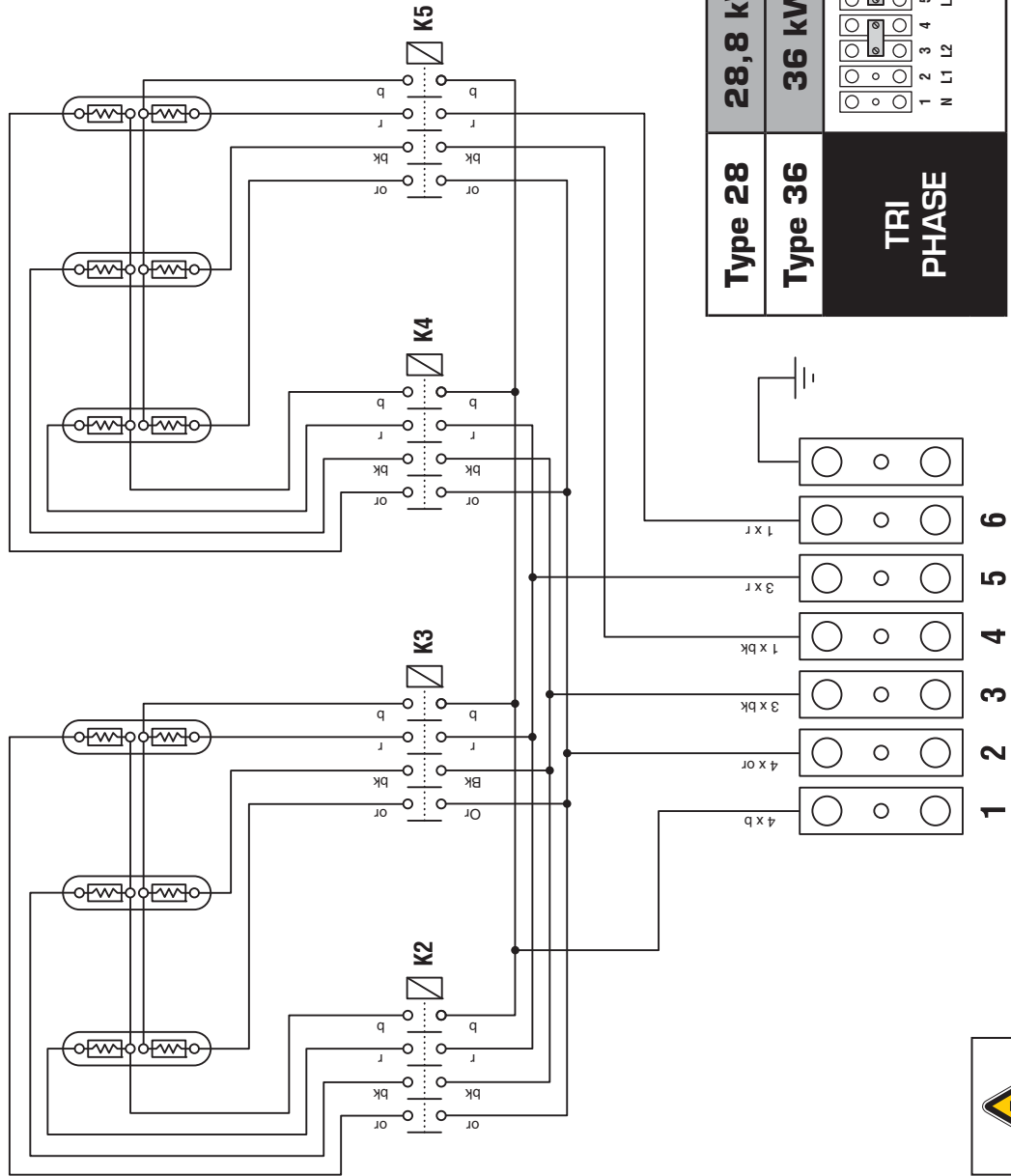

Type 28	28,8 kW	26,4 kW	24 kW	21,6 kW
Type 36	36 kW	33 kW	30 kW	27 kW
<b>TRI PHASE</b>				
Current not balanced				



# HONEYWELL SUNDIAL WIRING DIAGRAMS

## Honeywell Sundial Wiring Centre 'Y' Plan

**Note:** Earth wires not shown for clarity  
During installation the earth wires from each component connect to terminal 3 in the wiring centre

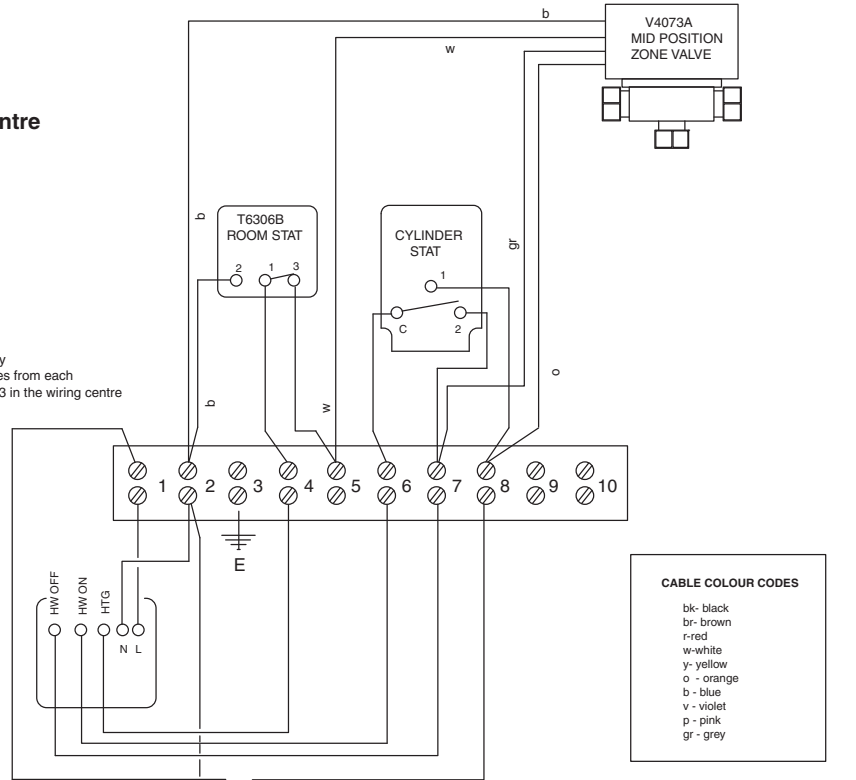

**Note:** All bold numbers indicate a DIN rail terminal connection

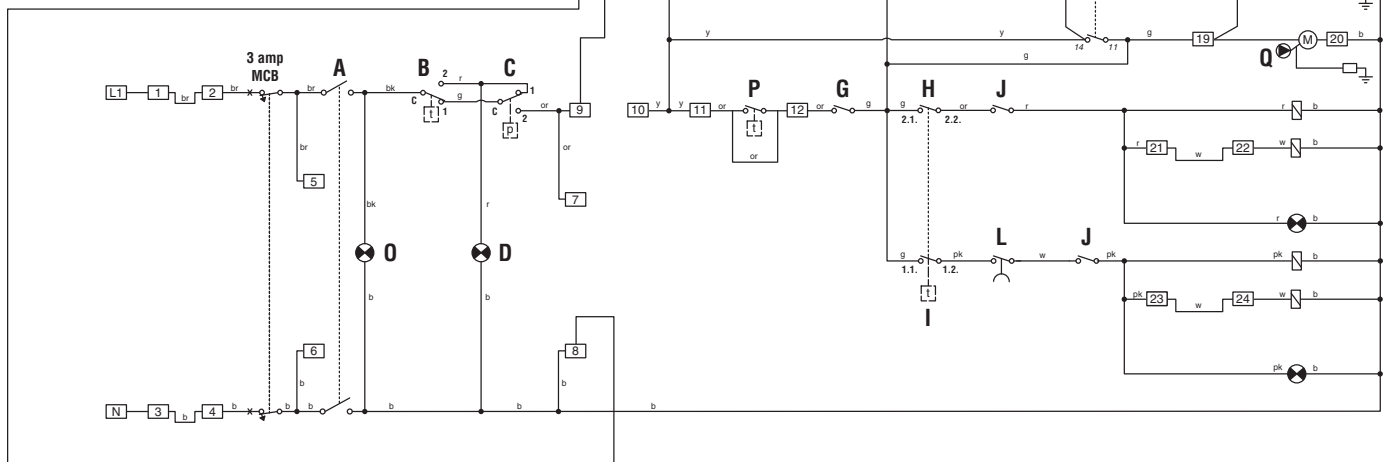

**Note:** Illustrated model = 28 kW - 36 kW Tri Phase

# COMMISSIONING AND MAINTENANCE

## COMMISSIONING - WATER

1. The system must be thoroughly cleansed prior to connection of the boiler. The system water should be treated to prevent general corrosion and deposition of scale or sludge in the boiler; please refer to BS7593. If installing the boiler onto an existing system, ACV recommend that an approved system cleaner is used.
2. Fill and pressurise the boiler and system to 1.5 bar, making sure to vent the boiler via the automatic air vent on top of the boiler. Note that the black dust cap on the air vent should be left loose to allow the auto vent to function.
3. Check for leaks.  
For specialist advice on water treatment products, contact:

Fernox, Britannia Works  
Clavering, Essex CB11 4QZ  
Tel 01799 550811

## COMMISSIONING - ELECTRICAL

The Electrical installation supplying this boiler must conform to the current IEE Regulations.

1. Remove the front panel and check all electrical connections for tightness.
2. Ensure all internal relays, contactors etc are secure on the DIN rails.
3. Set all panel control switches to off.
4. Check the power stage delay timer settings - Adjuster (A) is factory set to the 1 to 10 minute position which is the optimum setting for the boiler and should be verified during commissioning. - Adjuster (B) is used to set the DELAY ON time of the following stage contactors, the available settings are in 1 minute increments if A is set to 1 to 10 minutes.  
This function is particularly useful in areas where gradual switching of electrical load is required and the resulting maximum demand kept to a minimum. The timers add to the flexibility of the installation but must be optimised by a qualified engineer. The normal setting is 1.
5. Set internal MCB to off position.
6. Set the control thermostat to desired temperature.

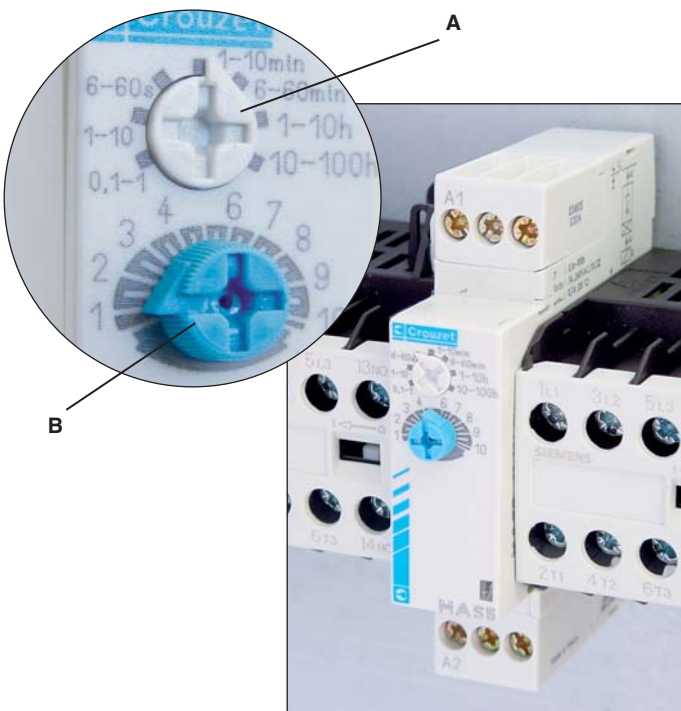

## STARTING THE BOILER

1. Switch on the internal or external timeclock (if fitted)
2. Switch on internal MCB
3. Switch on local isolator to boiler
4. Turn the boiler on using the ON/OFF switch
5. Switch on the power levels switch stage 1, the first stage contactors will energise
6. Switch on the power levels switch stage 2, after a short delay the second stage contactors will energise. Note: the power stage delay timer settings should be verified as shown in item 4 under "Commissioning - Electrical"
7. The boiler temperature will now rise as indicated by the combined temperature and pressure gauge
8. The temperature will continue to rise until the control thermostat temperature setting is reached then the boiler will switch off.

Once these procedures have been followed the system can be left to operate normally by the following method.

1. Ensure that boiler thermostat is set to the desired temperature
2. Turn the boiler on using the ON/OFF switch
3. Turn on power level switch 1
4. Turn on power level switch 2
5. Set timeclock (if fitted) and/or external controls to desired boiler operating on/off times.

After one week of operation all electrical connections should be re-checked for tightness and the boiler water system checked for leaks and air and rectified if necessary.

## MAINTENANCE

For safety reasons it is recommended that the boiler is serviced annually and that servicing is carried out by a qualified service engineer.

**Before carrying out any work on the system ensure that the boiler is cool and all electrical supplies are isolated.**

1. After removing front cover undo the four screws retaining the front control panel and gently let the panel suspend on the wiring to the rear of the panel. Undertake a visual inspection of the boiler looking out for signs of water leakage from joints, expansion vessel, and the area around the elements on top of the boiler.
2. Undertake a visual inspection of all cabling in the boiler casing checking for signs of overheating or burning.
3. Check all push-on electrical connectors for tightness and good connection to the relative components.
4. Using a correct fitting screwdriver check all electrical terminals on DIN rails and on all components for tightness.
5. Check the settings on the internal timers in accordance with the "Commissioning - Electrical" section.
6. Replace the control panel and the boiler front cover and refit screws.
7. Reinstate the electrical supply and follow the procedures set out in the commissioning section.

# REMOVAL THE HEATING ELEMENTS

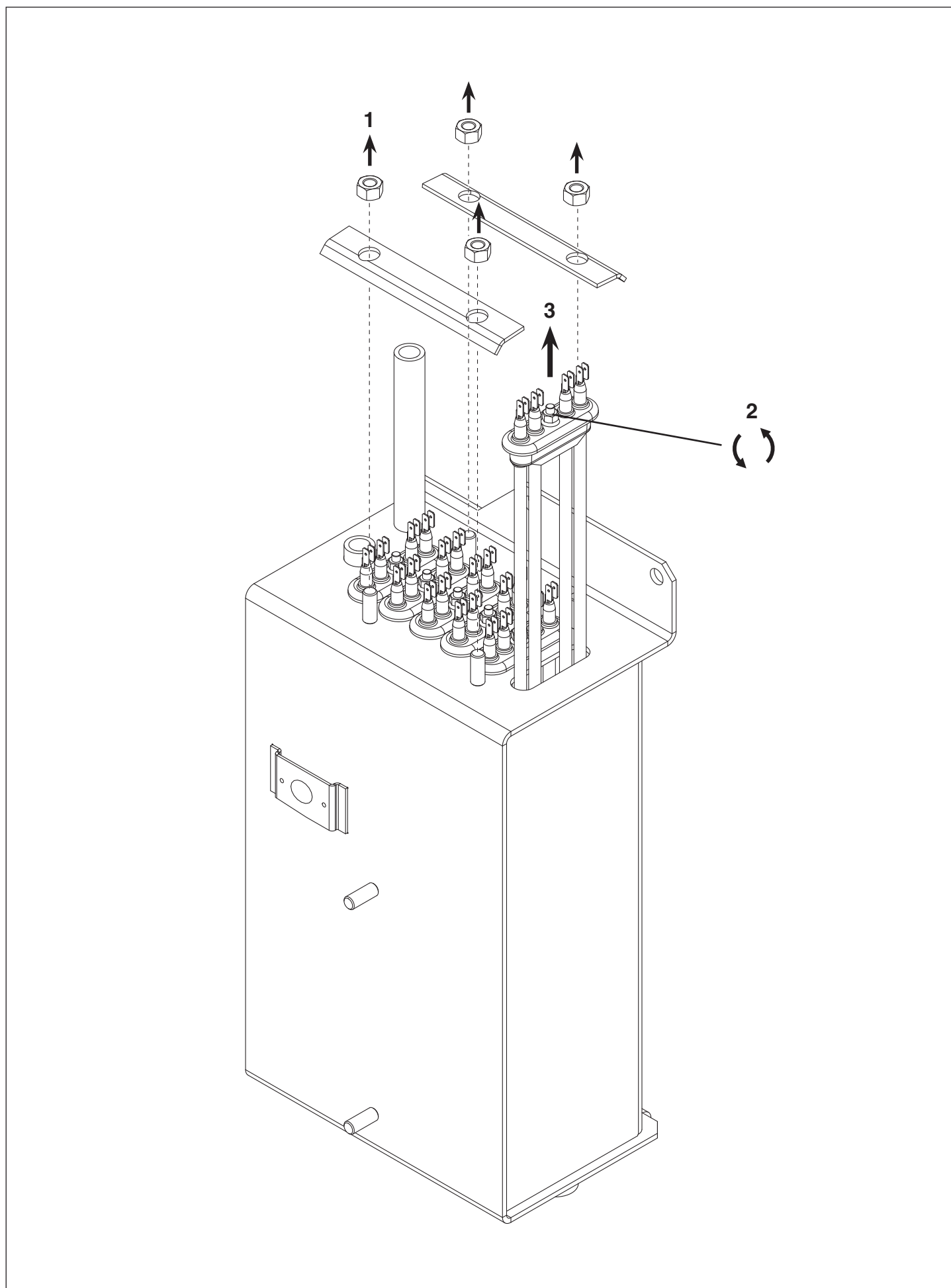













Handwriting practice area with multiple sets of horizontal lines (solid top and bottom lines with a dotted midline) for writing practice.





	<b>54428195</b>	<p>EN: Base for relay</p> <p>FR: Base pour relais</p> <p>NL: Relaisvoet</p>	<p>ES: Basa para relé</p> <p>IT: Base per relè</p> <p>DE: Relais-Sockel</p>
	<b>54766015</b>	<p>EN: Control circuit "Siemens"</p> <p>FR: Disjoncteur "Siemens"</p> <p>NL: ON/OFF-schakelaar "Siemens"</p>	<p>ES: Disyuntor "Siemens"</p> <p>IT: Interruttore ON/OFF "Siemens"</p> <p>DE: Siemens- Schutzschalter</p>
	<b>54452082</b>	<p>EN: Relay "Siemens" [3TG]</p> <p>FR: Relais "Siemens" [3TG]</p> <p>NL: Relais [3TG] "Siemens"</p>	<p>ES: Relé "Siemens" [3TG]</p> <p>IT: Relè "Siemens" [3TG]</p> <p>DE: Siemens-Relais [3TG]</p>
	<b>54428192</b>	<p>EN: Timer "Crouzet"</p> <p>FR: Temporisateur "Crouzet"</p> <p>NL: Timer "Crouzet"</p>	<p>ES: Temporizador "Crouzet"</p> <p>IT: Temporizzatore "Crouzet"</p> <p>DE: Crouzet-Zeitrelais</p>
	<b>54452092</b>	<p>EN: Blocking</p> <p>FR: Butée de blocage</p> <p>NL: Bevestigingsklem</p>	<p>ES: Tope de bloqueo</p> <p>IT: Blocco di arresto</p> <p>DE: Sperranschlag</p>
	<b>54767014</b>	<p>EN: Terminal WKN 16/U blue</p> <p>FR: Borne WKN 16/U bleu</p> <p>NL: Klem WKN 16/U blauw</p>	<p>ES: Borne WKN 16/U azul</p> <p>IT: Morsetto WKN 16/U blue</p> <p>DE: Klemme WKN 16/U bleu</p>
	<b>54428179</b>	<p>EN: Terminal 16 mm<sup>2</sup> WKN 16/U</p> <p>FR: Borne 16 mm<sup>2</sup> WKN 16/U</p> <p>NL: Klem 16 mm<sup>2</sup> WKN 16/U</p>	<p>ES: Borne 16 mm<sup>2</sup> WKN 16/U</p> <p>IT: Morsetto 16 mm<sup>2</sup> WKN 16/U</p> <p>DE: Klemme 16 mm<sup>2</sup> WKN 16/U</p>
	<b>54428091</b>	<p>EN: Terminal end APN 16 mm<sup>2</sup></p> <p>FR: Cache borne APN 16 mm<sup>2</sup></p> <p>NL: Klemafdekplaatje APN 16 mm<sup>2</sup></p>	<p>ES: Cubrebornes APN 16 mm<sup>2</sup></p> <p>IT: Coprimorsetto APN 16 mm<sup>2</sup></p> <p>DE: Klemmenabdeckung APN 16 mm<sup>2</sup></p>
	<b>54428155</b>	<p>EN: Terminal WKN10 sl/u</p> <p>FR: Borne WKN10 sl/u</p> <p>NL: Klem WKN10 sl/u</p>	<p>ES: Borne WKN10 sl/u</p> <p>IT: Morsetto WKN10 sl/u</p> <p>DE: Klemme WKN10 sl/u</p>
	<p><b>54428278 [2]</b></p> <p><b>54428279 [3]</b></p> <p><b>54428280 [4]</b></p>	<p>EN: Shunt IVBWKN</p> <p>FR: Pontage IVBWKN</p> <p>NL: Overbrugging IVBWKN</p>	<p>ES: Derivación IVBWKN</p> <p>IT: Ponticello IVBWKN</p> <p>DE: Überbrückung IVBWKN</p>



09

15

22

28

36

●

●

●

●

●

●

●

●

●

●

●

●

●

●

●

●

●

●

●

●

●

●

●

●

●

●

●

●

●

●

●

●

●

●

●

●

●

●

●

●

●

●

●

●

●

●









●

●

●

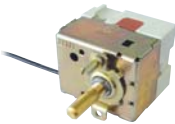
●



	<b>54767015</b>	<p>EN: Control terminal block</p> <p>FR: Bornier 28 pôles complet</p> <p>NL: Klemmenblok 28-polig, compleet</p>	<p>ES: Repleta de 28 bornes</p> <p>IT: Morsettiera 28 poli completa</p> <p>DE: Klemmenleiste, 28-polig, komplett</p>
	<b>54766016</b>	<p>EN: Green switch</p> <p>FR: Interrupteur vert</p> <p>NL: Schakelaar groen</p>	<p>ES: Interruptor verde</p> <p>IT: Interruttore verde</p> <p>DE: Schalter grün</p>
	<b>54766017</b>	<p>EN: Yellow switch</p> <p>FR: Interrupteur jaune</p> <p>NL: Schakelaar geel</p>	<p>ES: Interruptor amarillo</p> <p>IT: Interruttore giallo</p> <p>DE: Schalter gelb</p>
	<b>54763012</b>	<p>EN: Combined T° and pressure gauge Ø 40 mm</p> <p>FR: Thermonanomètre Ø 40 mm</p> <p>NL: Manothermometer Ø 40 mm</p>	<p>ES: Termomanómetro Ø 40 mm</p> <p>IT: Termomanometro Ø 40 mm</p> <p>DE: Thermomanometer Ø 40 mm</p>
	<b>54766001</b>	<p>EN: Red alarm indicator Ø 10 mm / 240 V</p> <p>FR: Lampe témoin rouge Ø 10 mm / 240 V</p> <p>NL: Controlelampje rood Ø 10 mm / 240 V</p>	<p>ES: Luz indicadora roja de Ø 10 mm / 240 V</p> <p>IT: Spia rossa Ø 10 mm / 240 V</p> <p>DE: Kontrollleuchte rot Ø 10 mm / 240 V</p>
	<b>54764017</b>	<p>EN: Control thermostat 2 stages</p> <p>FR: Thermostat de réglage 2 étages</p> <p>NL: Regelthermostaat, 2-traps</p>	<p>ES: Termostato de ajuste de 2 niveles</p> <p>IT: Termostato di regolazione 2 stadi</p> <p>DE: Einstellthermostat 2 Stufen</p>
	<b>54764021</b>	<p>EN: Button thermostat</p> <p>FR: Bouton thermostat</p> <p>NL: Thermostaatknop</p>	<p>ES: Botón del termostato</p> <p>IT: Manopola termostato</p> <p>DE: Thermostatknopf</p>
	<b>54764009</b>	<p>EN: Manual reset high limit thermostat 103°C</p> <p>FR: Thermostat réarmement manuel 103°C</p> <p>NL: Thermostaat met handmatige herinschakeling 103°C</p>	<p>ES: Termostato de rearme manual 103°C</p> <p>IT: Termostato a riarmo manuale 103°C</p> <p>DE: Manuell entriegelbarer Sicherheitsthermostat 103°C</p>
	<b>54428113</b>	<p>EN: Cable gland [PG29]</p> <p>FR: Presse-étoupe [PG29]</p> <p>NL: Kabelfitting [PG29]</p>	<p>ES: Prensaestopa [PG29]</p> <p>IT: Pressacavi [PG29]</p> <p>DE: Stopfbuchse [PG29]</p>
	<b>63438003</b>	<p>EN: Brass pocket</p> <p>FR: Doigt de gant</p> <p>NL: Voelerhuls</p>	<p>ES: Vaina</p> <p>IT: Pozzetto portasonda</p> <p>DE: Tauchhülse</p>



09

15

22

28

36

●

●

●

●

●

●

●

●

●

●

●

●

●

●

●

●

●

●

●

●

●

●

●

●

●

●

●

●

●

●

●

●

●

●

●

●

●

●

●

●

●

●

●

●

●

●

●

●

●

●



	<b>54428183</b>	EN: Heating element 2 x 1,4 kW FR: Élément chauffant 2 x 1,4 kW NL: Verwarmingselement 2 x 1,4 kW	ES: Elemento calefactor 2 x 1,4 kW IT: Resistenza elettrica 2 x 1,4 kW DE: Heizelement 2 x 1,4 kW
	<b>54428182</b>	EN: Heating element 2 x 2,4 kW FR: Élément chauffant 2 x 2,4 kW NL: Verwarmingselement 2 x 2,4 kW	ES: Elemento calefactor 2 x 2,4 kW IT: Resistenza elettrica 2 x 2,4 kW DE: Heizelement 2 x 2,4 kW
	<b>5476D004</b>	EN: Heating element 2 x 3 kW FR: Élément chauffant 2 x 3 kW NL: Verwarmingselement 2 x 3 kW	ES: Elemento calefactor 2 x 3 kW IT: Resistenza elettrica 2 x 3 kW DE: Heizelement 2 x 3 kW
	<b>557D3011</b>	EN: Water pressure switch FR: Pressostat de sécurité manque d'eau NL: Waterdrukschakelaar	ES: Presostato de seguridad en caso de falta de agua IT: Pressostato di sicurezza mancanza acqua DE: Wassermangel-Sicherheitsdruckschalter
	<b>557A4009</b>	EN: Circulating pump FR: Circulateur NL: Circulatiepomp	ES: Circulador IT: Circolatore DE: Pumpe
	<b>55426017</b>	EN: Pressure safety valve 3 bars Ø 1/2" FR: Soupape de sécurité 3 bars Ø 1/2" NL: Veiligheidsklep 3 bar Ø 1/2"	ES: Válvula de seguridad 3 bares Ø 1/2" IT: Valvola di sicurezza 3 bar Ø 1/2" DE: Sicherheitsventil 3 bar Ø 1/2"
	<b>55445007</b>	EN: Automatic air vent FR: Purgeur automatique NL: Automatische ontluchter	ES: Purgador automático IT: Valvola di spurgo aria automatica DE: Automatische Entlüftung
	<b>557A2012</b>	EN: Flexible tube FR: Flexible hydraulique NL: Flexibele hydraulische leiding	ES: Tubo flexible hidráulico IT: Flessibile di collegamento idraulico DE: Hydraulikschlauch
	<b>557A7006</b>	EN: Expansion vessel 10 litres FR: Vase d'expansion 10 litres NL: Expansievat 10 liter	ES: Vaso de expansión de 10 litros IT: Vaso di espansione 10 litri DE: Ausdehnungsgefäß 10 Liter
	<b>24614142</b>	EN: Complete control panel FR: Tableau de commande complet NL: Volledig bedieningspaneel	ES: Panel de mandos completo IT: Pannello di comando completo DE: Schaltfeld komplett



09	15	22	28	36
●	-	-	-	-
-	●	●	●	-
-	-	-	-	●
●	●	●	●	●
●	●	●	●	●
●	●	●	●	●
●	●	●	●	●
●	●	●	●	●
●	●	●	●	●
●	●	24614143	24614144	24614145



N°	EN	FR	NL	ES	IT	DE
A01	Side panel	Latérale	Zijkanten	Lateral	Pannelo laterale	Seitenteil
A02	Front panel	Face avant	Frontstuk	Parte delantera	Mantello anteriore	Vorderteil
A03	Top cover	Couvercle supérieur	Bovenkap	Tapa superior	Mantello superiore	Obere Abdeckung
A04	Rear panel	Panneau arrière	Achterpaneel	Panel posterior	Pannelo posteriore	Hintere Blende
A05	Control panel [ABS]	Tableau [ABS]	Paneel [ABS]	Panel [ABS]	Pannelo [ABS]	ABS-Tafel
A06	Wall mounting	Fixation murale	Wandbevestiging	Fijación mural	Staffa murale	Wandhalterung
A07	Body heating	Corps de chauffe	Ketellichaam	Cuerpo de calefacción	Corpo caldaia	Kesselkörper
A08	Control panel	Tableau de commande	Bedieningspaneel	Panel de mandos	Pannelo di comando	Schaltfeld
A09	Electric support	Support électrique	Verwarmings-compartiment	Soporte eléctrico	Supporto componenti elettrici	Socket für die Elektrik

